



TENDER T-03-2019

REHABILITATION OF CAVENDISH OUTDOOR RINK, TRENT LAKES, ON

PLEASE USE INK OR TYPEWRITER

NAME OF VENDOR OR INDIVIDUAL (THE BIDDER)

ADDRESS

MUNICIPALITY, TOWN OR VILLAGE

POSTAL CODE

TELEPHONE NO.

FAX NO.

E-MAIL ADDRESS

NAME OF PERSON SIGNING FOR FIRM

OFFICE OF PERSON SIGNING FOR FIRM

PART "A" INFORMATION TO BIDDERS	PAGES 2 - 5
PART "B" FORM OF TENDER (TO BE RETURNED WITH TENDER)	PAGES 6 - 21
PART "C" SPECIFICATIONS	
Special Provisions – General	PAGES 22 - 28
Special Provisions – Tender Items	PAGES 29 - 30
Section 13180 – Dasher Boards (5 pages)	
OPS General Conditions	PAGE 31
DRAWING SET	APPENDED

PART "A" - INFORMATION TO BIDDERS

1. SUBMISSION OF TENDER

Your tender must be made on this form and returned sealed in an envelope clearly marked as to contents,

NOT LATER THAN 2:00 P.M. LOCAL TIME

TUESDAY, June 25, 2019

Addressed to: Jessie Clark, Deputy Clerk
Municipality of Trent Lakes
760 County Road 36
Trent Lakes, ON. K0M 1A0

The time registered on the clock at Municipal Office Reception will be considered the official time when determining exact time of submission.

The following **MUST** be completed and submitted with your bid.

	Required	Not Required	Submitted
1. Identification Sheet	<input checked="" type="checkbox"/>	<input type="checkbox"/>	<input type="checkbox"/>
2. Acknowledgement of Documents Received by Bidder	<input checked="" type="checkbox"/>	<input type="checkbox"/>	<input type="checkbox"/>
3. Agreement to Terms and Conditions	<input checked="" type="checkbox"/>	<input type="checkbox"/>	<input type="checkbox"/>
4. Bid Sheets	<input checked="" type="checkbox"/>	<input type="checkbox"/>	<input type="checkbox"/>
5. Agreement to Bond	<input checked="" type="checkbox"/>	<input type="checkbox"/>	<input type="checkbox"/>
6. Bid Deposit	<input checked="" type="checkbox"/>	<input type="checkbox"/>	<input type="checkbox"/>
7. Surety Requirements	<input checked="" type="checkbox"/>	<input type="checkbox"/>	<input type="checkbox"/>
8. Contractor's Experience Record	<input checked="" type="checkbox"/>	<input type="checkbox"/>	<input type="checkbox"/>
9. Bidder's Senior Supervisory Staff	<input checked="" type="checkbox"/>	<input type="checkbox"/>	<input type="checkbox"/>
10. List of Sub-Contractors	<input checked="" type="checkbox"/>	<input type="checkbox"/>	<input type="checkbox"/>
11. Declaration Re Fairness is a Two Way Street Act	<input checked="" type="checkbox"/>	<input type="checkbox"/>	<input type="checkbox"/>

2. AWARD AND TERM OF CONTRACT

The lowest or any Tender may not necessarily be accepted and the Municipality reserves the right to reject any or all tenders.

PART “A”- INFORMATION TO BIDDERS

3. BID DEPOSIT AND PERFORMANCE SURETY REQUIREMENTS

3.1 BID DEPOSIT REQUIREMENTS

The bid shall be accompanied by a bid deposit in the form of a bid bond, certified cheque, bank draft, money order or irrevocable letter of credit made payable to the Municipality of Trent Lakes. The bid deposit shall be equal to or greater than the amount specified herein and **MUST BE ENCLOSED IN THE SAME ENVELOPE AS THE BID.**

<u>TOTAL AMOUNT OF BID</u>	<u>MINIMUM DEPOSIT REQUIRED</u>
\$20,000.00 or less	\$500.00
\$20,000.01 to \$50,000.00	\$1,000.00
\$50,000.01 to \$100,000.00	\$2,000.00
\$100,000.01 to \$250,000.00	\$9,000.00
\$250,000.01 to \$500,000.00	\$19,000.00
\$500,000.01 to \$1,000,000.00	\$40,000.00
\$1,000,000.01 to \$2,000,000.00	\$75,000.00
\$2,000,000.01 and over	\$150,000.00

All tender deposits will be returned to the respective bidders within ten (10) days after the Tenders have been opened except those which the Municipality elects to retain until the successful bidder has completed the Contract documents.

The tender deposit of the successful bidder will be returned when he has fully complied with the conditions outlined in the Tender Documents.

3.2 PERFORMANCE SURETY REQUIREMENTS

The successful vendor will be required to supply a Performance & Maintenance Bond and Labour and Material Payment Bond in the amount of:

One hundred (100%) percent of the Awarded Contract price.

The bonds to be issued by an approved Surety Company, licensed to do business in the Province of Ontario, on the forms attached to these documents or on other standard forms provided an approved Surety Company, for the faithful performance of this contract.

A fully executed Agreement to Bond shall be supplied with the Tender submission.

PART "A"- INFORMATION TO BIDDERS

4. INQUIRY

Any questions related to the tender must be submitted in writing no less than **3 business days prior to the closing date** and time indicated herein. Should the inquiry require issuance of an addendum, the addendum will be issued to all Bid Document Takers registered with the Municipality.

Contact information in reference to the tender drawings and specifications (email only):

Steve Clark, M.Sc., P.Eng.
WSP Canada Inc.
294 Rink Street, Suite 103
Peterborough, ON K9J 2K2
Email: Stephen.clark@wsp.com

Contact information in reference to the tender process (email only):

Jessie Clark, Deputy Clerk
Municipality of Trent Lakes
760 County Road 36
Trent Lakes, ON. K0M 1A0
Email: purchasing@trentlakes.ca

5. INSURANCE

The successful bidder will be required to furnish the Municipality of Trent Lakes within ten (10) calendar days of receiving the Acceptance Notice with proof of **Commercial General Liability Insurance** in an amount not less than: **\$5,000,000.00**
Motor Vehicle Liability Insurance of not less than: **\$2,000,000.00**

The Municipality of Trent Lakes and the WSP Canada Inc. are to be named as additional insured. The Bidder will be required to pay any deductible amounts in connection with all insurance policies.

Failure to provide such proof shall result in cancellation of the Contract and forfeiture of the bid deposit.

6. WORKPLACE SAFETY INSURANCE BOARD CLEARANCE CERTIFICATE

The successful bidder will be required to provide a current certificate of clearance from the Workplace Safety Insurance Board. If the Contractor is not required to provide coverage under the Act, a signed declaration indicating that they have complied with all provisions of the *Workplace Safety and Insurance Act, 1997, S.O. 1997, c.16 Schedule. A, as amended*, and its associated regulations, shall be provided to the Municipality within ten (10) calendar days of receiving the Acceptance Notice.

Failure to provide such proof shall result in cancellation of the Contract and forfeiture of the bid deposit.

PART "A"- INFORMATION TO BIDDERS

7. COMMENCEMENT DATE AND COMPLETION OF WORK

The Contractor shall commence work no sooner than **July 11, 2019** and after receipt of a letter to proceed from the Municipality and after the execution of the Contract documents, or issuance of Purchase Order as applicable.

It shall be the intent of this tender that once the Contractor commences work, continuous working days, (except Saturday, Sunday and Statutory Holidays unless prior approval given), shall be used to complete the work specified.

8. TIME OF COMPLETION AND LIQUIDATED DAMAGES

Time shall be of the essence of this Contract.

All work required, as detailed in this tender, shall be completed on or before the dates noted in the following schedule:

Substantial Completion: September 13, 2019

Total Completion: September 27, 2019

It is agreed by the Parties to the Contract that in case all the work called for under the contract is not finished, commenced, continuously furnished or completed within the time limit set forth, damage will be sustained by the Municipality and that it is and will be impracticable and extremely difficult to ascertain and determine the actual damages which the Municipality will sustain in the event of and by any reasons of such delay and the Parties hereto agree that the Contractor will pay to the Municipality the sum of One Thousand Five Hundred Dollars (\$1,500.00) for liquidated damages for each and every calendar day prescribed and it is agreed that this amount is an estimate of the actual damage to the Municipality which will accrue during the period in excess of the prescribed number of calendar days.

The Municipality may deduct any amount under this paragraph from any monies that may be due or payable to the Contractor on any account whatsoever. The liquidated damages payable under this paragraph are in addition to and without prejudice to any other remedy, action or alternative that may be available to the Municipality.

The Vendor shall not be assessed with Liquidated Damages for any delay caused by Acts of God or of the Public Enemy, Acts of the Province or of any Foreign State, Fire, Flood, Epidemics, Quarantine, Restrictions, Embargoes, Labour Disruptions, Strikes, Lockouts or delays of Sub-Contractors due to such causes, then the time shall be extended for a period of time equal to the time lost due to such delay.

9. BIDDERS TO INVESTIGATE

Bidders must satisfy themselves by personal examination of the site and by such other means, as they may prefer, as to the actual conditions and requirements of the work.

PART "B" FORM OF TENDER

ACKNOWLEDGEMENT OF DOCUMENTS RECEIVED BY BIDDERS

PART "A" INFORMATION TO BIDDERS	PAGES 2 - 5
PART "B" FORM OF TENDER (TO BE RETURNED WITH TENDER)	PAGES 6 - 21
PART "C" SPECIFICATIONS	
Special Provisions – General	PAGES 22 - 28
Special Provisions – Tender Items	PAGES 29 - 30
Section 13180 – Dasher Boards (5 pages)	
OPS General Conditions	PAGE 31
DRAWING SET	APPENDED

I/We, the undersigned, hereby acknowledge and confirm, on behalf of _____

That, I/We have received all of the above noted documents and have been provided with all the details required to permit me/us to submit a Bid on Tender T-03-2019

I/WE acknowledge that _____ addenda have been received and that it is my/our ultimate responsibility to ensure all addenda issued have been received.

The undersigned hereby agrees to provide the goods, services or construction specified in accordance with Parts "A", "B" and "C" of Tender T-03-2019 for the prices quoted in the schedule of prices enclosed herein. It is certified that the undersigned is/are authorized, appointed and empowered to sign and submit this bid.

Executed by me/us and bearing date this _____ day of _____, 2019.

NAME OF FIRM

DATED

PRINT NAME
(I have the authority to bind the Company/Corporation)

WITNESS
(If Corporate or Legal Seal Not Available)

POSITION IN FIRM

SIGNATURE

AFFIX CORPORATE OR LEGAL SEAL

PART “B” FORM OF TENDER

SCHEDULE OF PRICES

The bidder shall prepare this tender legibly in ink or digital format. Any changes, erasures or overwriting of the prices shall be initialed.

The bidder agrees to provide all labour, fuel, equipment and materials necessary to perform the identified work in accordance with the tender documents.

Quantities may be increased or decreased to meet budgeted amounts and any additional payment or reduction in payment shall be made at the unit prices quoted herein.

ITEM	DESCRIPTION	TOTAL PRICE (From Detailed Bid Sheets)
A	To provide all labour, fuel, equipment and materials necessary to perform the work on Cavendish Outdoor Rink, all in accordance with the tender documents.	\$ _____
SUBTOTAL		\$ _____
13% HST		\$ _____
TOTAL TENDER AMOUNT		\$ _____

H.S.T. No. _____

PART "B" FORM OF TENDER

SCHEDULE OF PRICES

ITEMIZED BID FOR CONTRACT NO. T-03-2019

In accordance with Tender Documents, the Contractor hereby offers to complete the work specified for the following unit prices:

Item No.	OPSS, Special Prov.	Description	Unit	Qty	Unit Price	Total
1	SP, 201	Bonds and Insurance, Site Preparation and Maintenance, Mobilization and Demobilization.	L.S.	1		
2	SP	Removals	L.S.	1		
3	SP	Perimeter Curb - Concrete	L.S.	100		
4	SP	Perimeter Curb - Waterstop	L.S.	100		
5	SP, 1350, 1440	Concrete Access Ramp	L.S.	1		
6	SP, 13180	Hockey Dasher Board System	L.S.	1		
7	SP	Dasher Board Installation Supervision	L.S.	1		
SP - Special Provisions OPSS - Ontario Provincial Standard Specs.				SUB-TOTAL (Transfer to Page 7)		\$ _____

PART "B" FORM OF TENDER

BOND NO. _____

AGREEMENT TO BOND

ADDRESSED TO: THE CORPORATION OF THE MUNICIPALITY OF TRENT LAKES
(Hereinafter referred to as the Owner)

DESCRIPTION AND
LOCATION OF PROJECT: Rehabilitation of Cavendish Outdoor Rink, Trent Lakes, ON

MUNICIPALITY OF TRENT LAKES
TENDER NO: T-03-2019

We, the undersigned, hereby agree to become bound as Surety, for

(The Contractor)

in a Performance and Maintenance bond for an amount equal to **100%** of the contract amount

in a Labour & Material Payment bond for an amount equal to **100%** of the contract amount.

on the bond forms provided herein or on forms of a Bank or similar institution registered in the Province of Ontario and conforming to the Instruments of Contract for the full and due performance of the work described above, if the tender submitted by the said Contractor for the work described above is accepted by the Municipality and if application for the said Bond or Bonds is made within sixty (60) days of the date of acceptance of the tender.

We, as Surety, are licensed to transact business in the Province of Ontario.

SIGNED, SEALED and DATED this _____ day of _____, 2019.

Witness: _____

Name _____

Address: _____

By: _____ **(SEAL)**
The Surety

PRINT NAME

By: _____
Attorney-in-Fact Signature

Attorney-in-Fact
PRINT NAME

PART "B" FORM OF TENDER

BID BOND

BOND NO. _____ \$ _____

KNOW ALL MEN BY THESE PRESENTS THAT _____

as Principal, hereinafter called the Principal, and _____

a corporation created and existing under the laws of Ontario, and duly authorized to transact the business of Suretyship in Ontario as Surety, hereinafter called the Surety, are held and firmly bound unto

THE CORPORATION OF THE MUNICIPALITY OF TRENT LAKES Obligee, hereinafter called the Obligee, in the amount of

_____ Dollars, (\$ _____) lawful money of Canada, for the payment of which sum, well and truly to be made, the Principal and the Surety bind themselves, their heirs, executors, administrators, successors and assigns, jointly and severally, firmly by these presents.

WHEREAS, the Principal has submitted a written tender to the Obligee, dated the _____ day of _____ 2019, for _____

NOW, THEREFORE, THE CONDITION OF THIS OBLIGATION is such that if the aforesaid Principal shall have the tender accepted within sixty (60) days from the closing date of tender and the said Principal will, within the time required, enter into a formal Contract and give the specified security to secure the performance of the terms and conditions of the Contract, then this obligation shall be null and void; otherwise the Principal and the Surety will pay unto the Obligee the difference in money between the amount of the bid of the said Principal and the amount for which the Obligee legally contracts with another party to perform the work if the latter amount be in excess of the former.

The Principal and the Surety shall not be liable for a greater sum than the specified penalty of this Bond.

PART "B" FORM OF TENDER

Any suit under this Bond must be instituted before the expiration of six months from the date of this Bond.

This Bid Bond applies only to a contract price not exceeding _____

IN WITNESS WHEREOF, The Principal and the Surety have signed and sealed this Bond this

_____ day of _____ 2019.

SIGNED, Sealed and
Delivered in the presence of

By: _____(Seal)
PRINCIPAL

WITNESS

_____(Seal)
SURETY

ADDRESS & PHONE NO. OF SURETY

By: _____
Attorney-in-Fact Signature

Attorney-in-Fact PRINT NAME

PART "B" FORM OF TENDER

BIDDER'S EXPERIENCE RECORD

The Bidder is required to supply at least three references for work completed in the last three years that is similar to the type of work to be completed under this Contract. The list provided may be contacted for references.

<p>Municipality/Company Name _____</p> <p>Contact Name & Phone No. _____</p> <p>Description of Work _____ _____</p> <p>Value of Work _____ When Completed _____</p>
<p>Municipality/Company Name _____</p> <p>Contact Name & Phone No. _____</p> <p>Description of Work _____ _____</p> <p>Value of Work _____ When Completed _____</p>
<p>Municipality/Company Name _____</p> <p>Contact Name & Phone No. _____</p> <p>Description of Work _____ _____</p> <p>Value of Work _____ When Completed _____</p>

PART "B" FORM OF TENDER

LIST OF SUB-CONTRACTORS

The Bidder shall provide a complete list of sub-contractors to be used on this contract for the approval of the Director or authorized designate. The Director or his authorized designate must approve any changes to the approved list prior to any work taking place.

SUB-CONTRACTOR	ADDRESS	TRADE

PART "B" FORM OF TENDER

DECLARATION

RE - FAIRNESS IS A TWO-WAY STREET ACT

I/We certify that neither my Company nor any proposed sub-contractor is a *person who is resident in a Designated Jurisdiction* in accordance with the Act.

I/We further acknowledge that any sub-contracts not identified in the bid following the award of the contract will be subject to the approval of the Municipality; and

I/We acknowledge that any material misrepresentation or breach of the representation and warranty of the Act will be grounds for termination of the contract.

Dated at the _____ this ____ day of _____, 2019.
(TOWN/MUNICIPALITY/REGION ETC.)

NAME OF FIRM OR INDIVIDUAL (THE BIDDER)

ADDRESS

MUNICIPALITY, TOWN OR VILLAGE

SIGNATURE OF WITNESS

SIGNATURE AND SEAL OF BIDDER

PRINT NAME OF PERSON SIGNING FOR FIRM

OFFICE OF PERSON SIGNING FOR FIRM

PART "B" FORM OF TENDER

PERFORMANCE & MAINTENANCE BOND

Bond No. _____

Contract No. **T-03-2019**

Account No. _____

KNOW ALL MEN BY THESE PRESENTS, that we _____

(The Contractor) hereinafter
called "The Principal", and

(The Bonding Company)

hereinafter called "The Surety" are jointly and severally held and firmly bound unto the Corporation of the Municipality of Trent Lakes hereinafter called "The Obligee", its successors and assigns, in the sum of \$_____ of lawful money of Canada to be paid unto the Obligee, for which payment well and truly to be made we the Principal and Surety jointly and severally bind ourselves, our and each of our respective heirs, executors, administrators, successors, and assigns by these presents.

SIGNED AND SEALED WITH OUR RESPECTIVE SEALS and dated this

_____ day of _____, 2019.

Whereas by an Agreement in writing dated the _____ day of _____, 2019 the Principal has entered into a contract with the Obligee, hereinafter called the "Contractor", for the:

Rehabilitation of Cavendish Outdoor Rink, Trent Lakes, ON

as in the contract provided, which contract is by reference herein made a part hereof as fully to all intents and purposes as though recited in full herein.

Now therefore the condition of this obligation is such that if the Principal shall at all times duly perform and observe the contract or as the same be changed, altered or varied as hereinafter provided, to the satisfaction of the Obligee and shall at all times fully indemnify and keep indemnified the Obligee from and against all and any manner of loss, damage, expense, suits, actions, claims, liens, proceedings, demands, awards, payments and liabilities arising out of or in any manner based upon or attributable to the contract and shall fully reimburse and repay the Obligee for all outlay, expense liabilities, or payments incurred or undertaken to be made by the Obligee pursuant to the contract, then this obligation shall be void, but otherwise it shall be and remain in full force and effect.

PART "B" FORM OF TENDER

PERFORMANCE & MAINTENANCE BOND

Provided always and it is hereby agreed and declared that the Obligee and Principal have the right to change, alter, and vary the terms of the contract and that the Obligee may in its discretion at any time or times take and receive from the Principal, any security whatsoever and grant any extension of time thereon or on any liability of the Principal to the Obligee.

Provided further and it is hereby agreed and declared that the Principal and the Surety shall not be discharged or released from liability hereunder and that such liability shall not be in any way affected by any such changes, alterations, or variations, taking or receiving of security, or extension of time, as aforesaid, or by the exercise of the Obligee of any of the rights or powers reserved to it under the contract or by its forbearance to exercise any such rights or powers, including (but without restricting the generality of the foregoing) any changes in the extent or nature of the works to be constructed, altered, repaired or maintained under the contract or any dealing, transaction, forbearance or forgiveness which may take place between the Principal and the Obligee.

Provided further and it is hereby agreed and declared that the Surety shall not be liable for a greater sum than that specified in this bond.

IN WITNESS WHEREOF THE PRINCIPAL AND SURETY HAVE EXECUTED THESE PRESENTS.

SIGNED, SEALED AND DELIVERED BY
THE PRINCIPAL IN THE PRESENCE OF

Witness signs here

PRINT NAME

Principal signs here
and seal where applicable. (Seal)

PRINT NAME & TITLE

SIGNED, SEALED AND DELIVERED BY
THE SURETY IN THE PRESENCE OF

Witness signs here

PRINT NAME

Attorney-In-Fact
signs here with seal (Seal)

PRINT NAME & TITLE

LABOUR AND MATERIAL PAYMENT BOND

BOND NO. _____ CONTRACT NO. T-03-2019

AMOUNT \$ _____

NOTE: This Bond is issued simultaneously with another Bond in favour of the Obligee conditions for the full and faithful performance of the Contract.

KNOW ALL MEN BY THESE PRESENTS, that we _____
(The Contractor) hereinafter
called "The Principal" and

(The Bonding Company)

hereinafter called (The Surety), are subject to the conditions hereinafter contained, held and firmly bound onto The Corporation of the Municipality of Trent Lakes as Trustee, hereinafter called "The Obligee", for the use and benefit of the Claimants, their and each of their heirs, executors, administrators, successors and assigns in the amount of

Dollars (\$ _____)

of lawful money of Canada for the payment of which sum well and truly to be made the Principal and the Surety bind themselves, their heirs, executors, administrators, successors and assigns jointly and severally, firmly by these presents.

WHEREAS, the Principal has entered into a written contract with the Obligee dated the _____ day of _____, 2019.

for the Rehabilitation of Cavendish Outdoor Rink in Trent Lakes including all labour, equipment and materials to remove and dispose of the existing hockey boards, mounting frames and hardware, concrete perimeter curb, installation of new perimeter curb complete with waterstop and drain pipes, installation of new hockey board system and associated work

which Contract Documents are by reference made a part hereof, and are hereinafter referred to as the Contract.

NOW, THEREFORE, THE CONDITIONS OF THIS OBLIGATION is such that, if the Principal shall make payment to all Claimants for all labour and material used or reasonably required for use in the performance of the Contract, then this obligation shall be null and void, otherwise it shall remain in full force and effect subject, however, to the following conditions:

- (1) A Claimant for the purpose of this Bond is defined as one having a direct contract with the Principal for labour, material, or both, used or reasonably required for use in the

performance of the Contract, labour and material being construed to include that part of water, gas, power, light, heat, oil, gasoline, telephone service or rental equipment directly applicable to the Contract provided that a person, firm or corporation who rents equipment to the Principal to be used in the performance of the Contract under a contract which provides that all or any part of the rent is to be applied towards the purchase thereof, shall only be a Claimant to the extent of the prevailing industrial rental value of such equipment for the period during which the equipment was used in the performance of the Contract. The prevailing industrial rental value of equipment shall be determined, insofar as it is practical to do so, in accordance with and in the manner provided for in the latest revised edition of the Ontario Ministry of Transportation schedule prior to the period during which the equipment was used in the performance of the Contract.

- (2) The Principal and the Surety hereby jointly and severally agree with the Oblige, as Trustee, that every Claimant who has not been paid as provided for under the terms of his contract with the Principal, before the expiration of a period of ninety (90) days after the date on which the last of such Claimant's work or labour was done or performed or materials were furnished by such Claimant, may as a beneficiary of the trust herein provided for, sue on this Bond, prosecute the suit to final judgment or such sum or sums as may be justly due to such Claimant under the terms of his said contract with the Principal and have execution thereon. Provided that the Oblige is not obliged to do or take any act, action or proceeding against the Surety on behalf of the Claimants, or any of them, to enforce the provisions of this Bond. If any act, action or proceeding is taken either in the name of the Oblige or by joining the Oblige as a party to such proceedings, then such act, action or proceeding shall be taken on the understanding and basis that the Claimants; or any of them, who take such act, action or proceedings shall indemnify and save harmless the Oblige against all costs, charges and expenses or liabilities incurred thereon and any loss or damage resulting to the Oblige by reason thereof. Provided still further that, subject to the foregoing terms and conditions, the Claimants, or any of them may use the name of the Oblige to sue on and enforce the provisions of this Bond.
- (3) No suit or action shall be commenced hereunder by any Claimant:
 - (a) unless such Claimant shall have given written notice within the time limits hereinafter set forth to each of the Principal, Surety and Oblige, stating with substantial accuracy the amount claimed. Such notice shall be served by mailing the same by registered mail to the Principal, Surety and Oblige at any place where an office is regularly maintained for the transaction of business by such persons or served in any manner in which legal process may be served in the Province or other part of Canada in which the subject matter of the contract is located. Such notice shall be given:

- (i) in respect of any claim for the amount or any portion thereof, required to be held back from the Claimant by the Principal, under either the terms of the Claimant's contract with the Principal, or under the Construction Lien Act legislation applicable to the Claimant's contract with the Principal, whichever is the greater, within one hundred and twenty (120) days after such Claimant should have been paid in full under the Claimant's contract with the Principal;
 - (ii) in respect of any claim other than for the holdback, or portion thereof, referred to above within one hundred and twenty (120) days after the date upon which such Claimant did, or performed the last of the work or labour or furnished the last of the materials for which such claim is made under the Claimant's contract with the Principal.
- (b) After the expiration of one (1) year following the date on which Principal ceased work on the Contract, including work performed under the guarantees provided in the Contract.
 - (c) Other than in a court of competent jurisdiction in the Province or other part of Canada in which the subject matter of the Contract or any part thereof is situated and not elsewhere, and the parties hereto agree to submit to the jurisdiction of such court.
- (4) The amount of this Bond shall be reduced by, and to the extent of any payment or payments made in good faith and in accordance with the provisions hereof, inclusive of the payment by the Surety of the Construction Lien Act which may be filed on record against the subject matter of the contract, whether or not claim for the amount of such lien be presented under and against this Bond.
 - (5) The Surety shall not be liable for a greater sum than the specified penalty of this Bond.

IN WITNESS WHEREOF, the Principal and the Surety have signed and sealed this Bond.

SIGNED AND SEALED
IN THE PRESENCE OF:

WITNESS SIGNS HERE

_____(SEAL)
PRINCIPAL SIGNS HERE WITH SEAL

By _____(SEAL)
ATTORNEY-IN-FACT
SIGNS HERE WITH SEAL

PART "B" FORM OF TENDER

NOTICE OF NO BID

It is important that the Municipality of Trent Lakes receive a reply from all invited bidders. There is no obligation to submit a tender, quotation or proposal; however, should you choose not to bid, completion of this form will assist the Municipality in determining the type of goods or service you are interested in bidding on in the future. Failure to submit a Bid or Notice of No Bid may result in the removal of your company from the Municipality's List of Bidders.

Circle the number(s) indicating your reason for not bidding, or explain briefly in the space provided. It is not necessary to return any other portion of the bid document if you are **not** bidding. Please return the completed form to the Municipal office.

- We do not offer this commodity/service
 - We do not manufacture/supply to this specification
 - Our schedule would not permit us to perform
 - Insufficient time to respond
 - We are unable to meet bonding requirements
 - We are unable to meet insurance requirements
 - Unable to bid competitively
 - Quantity/work too large
 - Quantity/work too small
 - Cannot meet delivery/completion requirements
 - Other reasons/additional comments _____
- _____

COMPANY NAME (PRINTED)

PRINT NAME

DATE

SIGNATURE

Failure to reply to this tender may result in the removal of your company's name from the Municipality's list of bidders.

PART “C” SPECIFICATIONS

SPECIAL PROVISIONS – GENERAL

1. Scope of Work

The scope of work shall comprise the rehabilitation of the Cavendish Outdoor Rink in the Municipality of Trent Lakes. The work shall include the removal of the existing board system, frames and mounting hardware, removal of the existing concrete perimeter curb, installation of a new perimeter curb complete with waterstop, drain pipes through the curb in four corners, and installation of new perimeter hockey boards complete with all mounting frames and hardware, equipment and player access gates. The work shall also include all temporary and permanent associated installations necessary to complete the work.

2. Budget Restrictions

Bidders are advised that due to budget or any reasons whatsoever, the Owner may elect to reduce the scope of work.

3. Bidders to Investigate

Bidders must satisfy themselves by personal examination of the site and by such other means as they may prefer as to the actual conditions and requirements of the work.

The Bidder shall carefully examine all plans and profiles so that the unit prices tendered are commensurate with the nature of the work. It shall be the Contractor's responsibility to thoroughly inspect the site of the proposed works, determine the location of any buried or obstructing services and make satisfactory arrangements for interference with such service with the proper jurisdictional agency.

PART "C" SPECIFICATIONS

SPECIAL PROVISIONS – GENERAL

**4. Property Owner's Release of Privately Owned Land
Used by the Contractor**

Upon completion of the Contract, the Contractor shall provide the Owner with two (2) copies of a form of release signed by each property owner, upon whose land they have entered for any purpose in conjunction with the Contract, as follows:

Date _____

To: Municipality of Trent Lakes
760 County Road 36
Trent Lakes, ON. K0M 1A0

Re: Contract No. T-01-2019

Attention: Jessie Clark

Dear Ms. Clark:

I hereby certify that _____
(Name of Contractor)

have fulfilled the terms of our agreement and have left my property in a satisfactory condition.

I release _____
(Name of Contractor)

The Corporation of the Municipality of Trent Lakes and the WSP Canada Inc. from further obligations.

Yours very truly,

Signature

Property Owner's Name _____ Lot _____ Concession _____

Municipal Address _____

Municipality of _____

(Please complete above in printing)

Final payment will not be released to the Contractor until all applicable forms of release have been signed by the property owner and received by the Municipality.

PART “C” SPECIFICATIONS

SPECIAL PROVISIONS – GENERAL

5. Payments

Except as herein provided, payments under this Contract will be made in accordance with Ontario Provincial Standard GC8 Measurement and Payment.

Holdback equal to 10% of the value of work performed, shall be retained until the expiry of sixty (60) days from the date of publication of the Certificate of Substantial Performance in a construction trade newspaper, following which, holdback shall be released providing there are no outstanding deficiencies, claims or liens.

6. Labour Conditions

The Contractor's attention is drawn to the fact that this contract falls under the jurisdiction of the Ministry of Labour and therefore the Roads and Structures Fair Wage Schedule, Labour Conditions and Interpretations for the Provincial Zone are to be applied. Any increase in costs incurred by a change in the wage rate shall be borne by the Contractor.

7. Employment

The Contractor and any Sub-Contractor of the Contractor shall:

1. Employ only residents of Canada; and
2. In employing persons, refrain from discriminating against any person by reason of race, religious view or political affiliations.

8. Disposal of Surplus or Unsuitable Material

Materials which are either unsuitable or surplus to the requirements of the Contract and which are to be disposed of shall be disposed of in full accordance with all applicable regulations in waste disposal areas arranged for by the Contractor and at no cost to the Owner. The Contractor shall include Tipping fees and all other related costs in the price of the appropriate item.

For disposal sites of the contract, written permission from the owner of the property upon which there is to be disposal, shall be obtained and filed with the Municipality prior to any disposal and shall save the Owner harmless from all claims that may arise from such disposal.

PART "C" SPECIFICATIONS

SPECIAL PROVISIONS – GENERAL

9. Revision to OPS General Conditions

Payment on a Time and Material Basis:

Section GC8.02.04.01, Definitions, is hereby revised by the addition of the following under "Payroll Burden".

Payment in respect of payroll burden shall be made at the following rates currently in effect:

- (i) Road Work - 26% of the wages and salary portion of the labour costs.
- (ii) Structure Work - 30% of the wages and salary portion of the labour costs.

10. Utilities

Sections GC2.01 and GC7.12.02 of the General Conditions are deleted in their entirety and are replaced by the following:

The Contractor shall be responsible for the protection of all utilities at the job site during the time of construction. **Contractor is advised there is electrical service to stand-alone two (2) light standards adjacent to the rink.**

The Owner will be responsible for the relocation of utilities where required. However, no claims will be considered which are based on delays or inconvenience resulting from the relocation not being completed before the start of this Contract.

The identification, location and depth of underground utilities, if shown on the Contract drawings, are based on the investigations made by the Owner. It is, however, the Contractor's responsibility to contact the appropriate agencies for further information in regard to the exact location of all utilities, to exercise the necessary care in construction operations and to take such other precautions as are necessary to safeguard the utilities from damage.

The Contractor is responsible for verification of the location and type of other utilities within the contract limits and which may be encountered during construction.

11. Traffic Control, Flagging

No traffic control is required for this Contract. Contractor will be provided with a layout area adjacent to the work site, if required.

PART “C” SPECIFICATIONS

SPECIAL PROVISIONS – GENERAL

12. Spills Reporting

Spills or discharges of pollutants or contaminants under the control of the Contractor, and spills or discharges of pollutants or contaminants that are a result of the Contractor's operations that cause or are likely to cause adverse effects shall forthwith be reported to the Contract Administrator. Such spills or discharges and their adverse effects shall be as defined in the Environmental Protection Act R.S.O. 1980.

All spills or discharges or liquid, other than accumulated rain water, from luminaires, internally illuminated signs, lamps, and liquid type transformers under the control of the Contractor, and all spills or discharges for this equipment that are a result of the Contractor's operations shall, unless otherwise indicated in the Contract, be assumed to contain PCB's and shall forthwith be reported to the Contract Administrator.

This reporting will not relieve the Contractor of his legislated responsibilities regarding such spills or discharges.

13. Layout

In accordance with Section GC7.02 of the General Conditions of the Contract, the Contractor shall be responsible for all layout required to accommodate the construction of this Contract.

14. Engineer's Field Office

Not required for this Contract.

15. Underground Municipal Services Marking

The Contractor is advised electrical service is provided to two (2) existing light standards to remain. No subsurface excavation is expected for the assignment.

16. Award of Contract

Bidders are advised that tenders will be reviewed as to lowest price, qualifications, capabilities, experience and the Contractors ability to complete the project within the time frame allowed. Lowest or any tender will not necessarily be accepted.

17. Emergency and Maintenance Measures

Whenever the construction site is unattended by the general superintendent, the name, address and telephone number of a responsible official of the contracting firm, shall be given to the Contract Administrator. This official shall be available at all times and have the necessary authority to mobilize workmen and machinery and to take any action as directed by the Contract Administrator in case emergency or maintenance measures are required regardless whether the emergency or requirement for maintenance was caused by the Contractor's negligence, act of God, or any cause whatsoever.

Should the Contractor be unable to carry out immediate remedial measures required, the Owner will carry out the necessary repairs, the costs for which shall be charged to the Contractor.

18. Dust Control

As a part of the work required under Section GC7.06 of the General Conditions, the Contractor shall take such steps as may be required to prevent dust nuisance resulting from his operations either within the right-of-way or elsewhere or by public traffic where it is the Contractor's responsibility to maintain a roadway through the work. The Contractor shall work cooperatively with residents to minimize disruption.

Where the work requires the sawing of asphalt or the sawing or grinding of concrete, blades and grinders of the wet type shall be used together with sufficient water to prevent the incidence of dust, wherever dust would affect traffic or wherever dust would be a nuisance to residents of the area where the work is being carried out.

The cost of all such preventative measures shall be borne by the Contractor except however where calcium chloride or water is used to reduce the dust caused by traffic on a roadway which it is the Contractor's responsibility to maintain for public traffic, the cost of such quantities of calcium chloride or water as are authorized by the Contract Administrator to restrict dust to acceptable levels, shall be paid for by the Owner at the contract prices for applicable item.

19. Protection of Water Quality

At all times, the Contractor shall control all construction work so as not to allow sediment or other deleterious materials to enter the watercourse. No waste or surplus organic material including topsoil is to be stored or disposed of within 30 metres of any watercourses. Run-off from excavation piles will not be permitted to drain directly into watercourses. Where this measure is not sufficient or feasible to control sediment entering the watercourses, sedimentation traps or geotextile coverage will be required.

If dewatering is required, the water shall be pumped into a mud mat and not pumped directly into the watercourses.

The Contractor shall not carry out equipment maintenance or refueling or store fuel containers within 30 metres of any watercourses. The Contractor shall not stockpile construction debris or empty fuel/pesticide containers within the Contract limits.

20. OPS General Conditions

Wherever in this Contract reference is made to the General Conditions, it shall be interpreted as meaning the OPS General Conditions of Contract, November 2018.

21. Contractor's Supply of Construction Signs

In accordance with Section GC7.06 of the General Conditions, the Contractor is responsible for the supply, erection, maintenance and subsequent removal of all temporary traffic controls, including signs, lights, barricades, delineators, cones, etc., required on the work.

23. Access to Community Centre and Safety Fencing

The Contractor shall ensure that safe access is provided to the Community Centre at all times. The rink is located approximately 60m from the Community Centre. Contractor shall supply and install safety fencing around the entire perimeter of the work area to the satisfaction of the Owner.

24. Geotechnical Report

No geotechnical report is available.

PART “C” SPECIFICATIONS

SPECIAL PROVISIONS – TENDER ITEMS

Bonds, Insurance and Mob/Demob

Item No. 1

The lump sum price bid for this item shall include all labour, equipment and material to provide the required securities, mobilization and demobilization, and other miscellaneous work necessary to permit the full installation of all components indicated or implied on the drawings and in the Contract documents and not included in other Tender Items. This item shall also include the supply and installation of safety fencing around the perimeter of the construction area at the start of construction and removal when site work is complete.

Payment for this item will be 50% on the first payment draw and based on estimated percentage complete, as determined by the Engineer, for subsequent payment requests. The balance of the payment for this item except for statutory holdback, will be released on the final payment request.

Removals

Item No. 2

The lump sum price bid for this item shall include all labour, equipment and material to remove and legally dispose of the existing hockey boards, mounting brackets and hardware, concrete curb to facilitate installation of new components.

The curb removal shall be completed in general conformance with OPSS 928. All saw cuts shall be straight and true, and include horizontal cutting of the existing curb and rebar parallel to the top of the main concrete slab to remain. Water shall be used during cutting operations to mitigate dust generation. Any areas of the existing concrete slab damaged during removal shall be repaired with an approved Sika product prior to installation of new curb.

Perimeter Concrete Curb

Item No. 3

The per metre price bid for this item shall include all labour, equipment and materials to supply and install a new concrete perimeter curb on the existing concrete slab including preparation of the sawn surface of the removed perimeter curb to accept the new concrete curb. Concrete shall be 5-8% air entrainment, slump 150-170 and minimum 28MPa at 28-days. Installation shall include 250mm long x 10M rebar on 600mm c/c set into predrilled holes (nominal 150mm deep) with epoxy and waterstop, as noted below.

The approximate perimeter length is 100 m.

Perimeter Water Stop

Item No. 4

The per metre price bid for this item shall include all labour, equipment and materials to supply and install waterstop to prevent water migration along the joint between the existing concrete slab to remain and the new concrete curb. The waterstop shall be Sika Greenstreak 655 or approved equivalent, attached to the existing concrete slab with stainless steel anchor bolts and tied with wire to the rebar to prevent movement during installation of the concrete curb.

The approximate perimeter length is 100 m.

Concrete Pad at Machine Access Gate

Item No. 5

The lump sum price bid shall include all costs for labour, equipment and materials to supply and install a reinforced concrete access ramp at the machine access gate as per the Contract drawings. The access ramp shall be installed flush to the top of the curb and tied to the existing concrete with rebar dowels epoxied into the concrete to remain.

Hockey Dasher Board System

Item No. 6

The lump sum price bid shall include all costs for labour, equipment and materials to supply and install new hockey dasher boards on the perimeter curb. The bid price shall be inclusive of all frames, brackets, anchors, gates and all other board components in accordance with Section 13180 below for the full and complete installation as indicated on the Contract Drawings.

The installation shall be completed in strict adherence to the manufacturer specifications and requirements. Installation shall be as directed by a representative of Athletica Sports Systems or their designate. A separate allowance has been included on the Bid Form for the authorized representative.

Dasher Board Installation Supervision

Item No. 7

The lump sum price bid shall include all costs for labour, travel and accommodation for an authorized representative of the manufacturer to provide on-site supervision of the installation of the dasher board system.

OPS Volume 7
OPS GENERAL CONDITIONS OF CONTRACT
and
GENERAL & CONSTRUCTION SPECIFICATIONS
NOVEMBER 2018

The General Conditions have not been reproduced as part of these Contract Documents.

It is the Contractor's responsibility to obtain current copies of
OPS Volume 7

APPENDIX A

SECTION 13180 – DASHER BOARD SYSTEM

Dasher Board Specification

Basis: Athletica Sport Systems 3” Pro Series™

SECTION 13180

PART 1 GENERAL

1.01 GENERAL

- A. Comply with requirements of General and Supplementary Conditions, and Division 1, General Requirements.

1.02 SECTION INCLUDES

- A. The work of this Section shall include, but not be limited to, the following:
 - 1. Manufacture, supply and installation of a complete factory prefabricated, arena board system as indicated on the drawings and specified herein.

1.03 RELATED SECTIONS

- A. Provide clear access into the rink area by forklift.
- B. Final cleaning to be carried out as directed by the Owner.

1.04 UNIT PRICES

- A. Submit unit prices stating the increase or decrease to the Contract Price for additional or deleted work listed. This will allow accurate “apples-to-apples” comparison between all base system bid prices. Unit prices shall include all labour, materials, products, equipment, services and respective overhead, profit, taxes, disbursements and related charges, and shall represent the actual addition or credit to the Contract Price.

1.05 SUBMITTALS

A. Shop Drawings

- 1. Shop drawings shall be submitted by manufacturer. Drawings shall be submitted to the Engineer for approval prior to actual fabrication of materials.
- 2. Shop drawings shall show, in appropriate scale, dimensions, details of arena board system, methods of joining, fastening, joint locations, methods of anchoring, sizes of anchorages, hardware, details of other pertinent components of the work, and adjacent constructions to which work of this Section will be attached.
- 3. Shop drawings shall indicate dimensioned layout and placement drawings for installation of anchors.

B. Samples

- 1. Submit samples of materials, finishes and colours for review.

C. Operation and Maintenance Data

- 1. On completion of installation, supply three copies of instructions covering adjustments and other relevant operating and maintenance data.
- 2. Provide “As Built” drawings showing overall layout of the boards and fencing.

1.06 QUALITY ASSURANCE

A. Qualifications

- 1. All materials shall be manufactured and installed per plans and specifications. Any deviations to this specification, unless approved in writing by the owner, will be charged back to the supplier at the Owner’s discretion.

B. MANUFACTURERS

The following manufacturers are acceptable:

1. **Athletica Sport Systems**
554 Parkside Drive, Waterloo, Ontario, Canada N2L 5Z4
Phone: 519.747.1856 Toll-free: 1.877.778.5911 Fax: 519.747.3659
- AND -
17200 Medina Rd., Suite 600, Minneapolis, Minnesota, USA 55447
Phone: 763.249.7465 Toll-free 1.800.809.7465 Fax: 763.249.7475
www.Athletica.com
2. **Other Approved Manufacturers**
Arena board system shall be provided by an approved manufacturing firm having satisfactory experience in manufacturing and installing arena boards, using persons trained and skilled in the type of work required for both manufacturing and installing. Firm must be approved PRIOR to bid and must provide evidence of at least ten (10) installations identical in construction and features to the following specification, each with a minimum of five (5) years' operating successfully prior to bid date. A list of these installations including arena name, contacts, address and telephone numbers must be included with requests for prior approval. A sample panel showing how the system is manufactured, including all features listed in this specification, must be submitted and approved prior to bid.
3. Steel framed dasher board systems are not an acceptable alternate for this scope of work.

1.07 WARRANTY

- A. Warrant the work of this Section against defects in materials and workmanship for a period of one (1) year from the date of substantial completion of the contract. Misuse, abuse and/or accident not caused by normal use is excluded. Board misalignment from ice build-up underneath, excessive ice edge or ice thickness beyond 1-1/2" is excluded. Exclusions are considered maintenance requirements.

1.08 DELIVERY

- A. Delivery and installation shall allow for enough manufacturing and installation time prior to the project completion date and mutually agreeable between Owner and Manufacturer.

PART 2 PRODUCTS

2.01 RINK DIMENSIONS

- A. Rink size shall be nominally 36.5m long x 18.0m wide x 4.6m radius corners or shown on drawings. Size shall be field verified by manufacturer.

2.02 MATERIALS

- A. Aluminum Extrusions: ASTM B221, 6005-T5 or T6 alloy and temper
- B. High Density Polyethylene UV-Stabilized, High impact, integrally coloured, high-density polyethylene, bright white and other colours as specified, 1/2" thickness.
- C. Fencing: n/a
- D. Posts: 1 11/16" diameter CQ20 galvanized piping c/w top and bottom members, tension bars, caps, etc. as required for a complete installation.

2.03 FABRICATION

- A. **General**
1. As far as practical, execute fitting and assembly in the shop with the various parts or assemblies ready for erection at the project site.

2. Accurately fit together all joints, corners and intersections. Match components carefully to produce continuity of line and design.
3. Provide devices for anchoring the assemblies to the substrate with adjustment to permit correct and accurate alignment.
4. Fabricate anchoring devices required to secure the work of this Section. Supply anchors and layout drawing.
5. System components shall be numbered for ease of installation, disassembly, and reinstallation.

2.04 SYSTEM DESCRIPTION FOR BASE BID REQUIREMENTS

A. Arena Panels

1. Arena panels shall be factory prefabricated in demountable sections. The design of all panels whether straight, curved or in which a gate is located shall be similar. Each panel to be 42" (1067mm) in height and shall be made of extruded structural aluminum box sections assembled into frames using high strength fasteners. Aluminum to be mill finish. Frames shall allow for fastening of the (UV-STABILIZED HDPE) facing and anchoring at base. Ensure flush mating of the (UV-STABILIZED HDPE) facing at arena panel joints.
2. Typical sections shall consist of a minimum two vertical posts (3 for outdoor systems), and three horizontal stringers. Frames shall be connected end to end with heavy duty, 5/8" (16mm) bolts and shall be connected to rink slab/perimeter concrete structure with minimum 5/8" (16mm) threaded rods and nuts or bolts, epoxied into the perimeter concrete. Standard size of straight arena panels shall be 2438 mm (8'-0") long, and 1067 mm (3'-6") high.
3. Cladding: The playing surface side of the arena panel shall be faced with 12 mm (1/2") nominal thickness, high impact, integrally coloured white high-density polyethylene (UV-STABILIZED HDPE) facing. Both sides of the arena facing shall have smooth surfaces. Colour of arena facing shall be identical on both sides.
4. The (UV-STABILIZED HDPE) facing shall be attached to the arena board framing with 6 mm (1/4") diameter screws. Heads of screws shall be painted to colour match arena facing, kickplate and cap rail, as appropriate. Spacing of the screws shall not exceed 305 mm (12") on centre. **For outdoor applications, facing shall be attached in two pieces per 8' panel, each piece being 48" long, and attached to the middle vertical post with screws as described above.**
5. Colour extensions of red and blue lines shall be coloured (UV-STABILIZED HDPE) strips inlaid flush to the facing and the kickplate in conformance with NHL (or IIHF) rink layout requirements.
6. Provide a 12 mm (1/2") thick colour impregnated (UV-STABILIZED HDPE) cap rail fastened to top horizontal framing member. Both edges of cap rail shall have a smooth and radiused edge.
7. Standard colour of cap rail shall be selected from manufacturer's standard colour range.

B. Players, Penalty, and Officials' Boxes/Benches

1. n/a

C. Gates

1. Access gates shall be built into standard 2440 mm (8'-0") sections and shall be 915 mm (3'-0") wide, left- or right-hand swing. Gate latch shall be a single latch type, with rink side access.
2. Players gates shall be built into standard 2440 mm (8'-0") sections and shall be 760 mm (2'-6")

wide, left- or right-hand swing. Gate latch shall be a single latch type with rink side access.

3. A flush mounted push-button latch shall be incorporated in the top sill of the cap rail on the playing surface access gates. The push button shall be 3" in diameter. The push-button shall be designed to be simple to operate yet prevent accidental opening.
4. Equipment gates shall be double gates with a 2440 mm (8'-0") opening. Gates shall be provided with two clamping handles and one retractable pin. Each equipment gate unit shall be equipped with adjustable heavy-duty spring-loaded swivel casters and adjustable tie-rod tension bars.
5. Hinge assemblies shall be constructed of 6mm (1/4") stainless steel. The hinge pins shall be minimum 16 mm (5/8") diameter.

D. **Spectator Shielding [Protective Fencing]**

1. n/a.

E. **Kickplates**

1. Kickplates shall be fabricated of 12 mm (1/2") thick nominal (UV-STABILIZED HDPE) colour impregnated sheets in 220 mm x 2440 mm (7 7/8" x 8'-0") segments. The kickplate shall be fastened to the bottom of the arena panel using fasteners coloured to match the kickplate.
2. Standard colour of kickplate shall be yellow.

F. **Thresholds**

1. Thresholds of access gates shall be 38 mm (1 1/2") above floor [rink] level.

G. **Board Anchors**

1. All arena boards shall be tightly fastened to the perimeter slab by means of zinc plated bolts or threaded rods and nuts. Anchors: Galvanized Steel or Zinc plated, permanent drilled on site anchor bolt system for securing to concrete substrate. Threaded rod and nuts for perimeter curb installation.

H. **Spare Components**

Supply, in addition to quantities required for the Work, extra materials and products to the owner:

1. Fifty (50) additional painted screws of each colour required for fastening of facings.

PART 3 EXECUTION

3.01 EXAMINATION

- A. Before commencing erection and installation, examine the work of other Sections to which the work of this Section will be attached.
- B. Report immediately in writing to the Engineer, all discrepancies in accuracy and suitability, conditions that will adversely affect the installation and permanency of the work of this Section.

3.02 INSTALLATION

A. General

1. Provide a **complete installation of the board system** by the manufacturer or manufacturer approved dealer in accordance with the drawings and specifications.
2. Installation shall be in strict conformance with the manufacturer's requirements and instructions.

- B. **Adjusting**
 - 1. Upon completion of the Work of this Section, inspect, test and adjust installation.
 - 2. Test all operable elements and ensure easy and smooth operation.
 - 3. Upon completion of installation do a general clean-up.
- C. **Cleaning**
 - 1. Final cleaning to be carried out as part of General Conditions.

PART 4 OPTIONAL FEATURES

Submit unit prices stating the increase or decrease to the Contract Price for additional or deleted work listed below. Unit prices shall include all labor, materials, products, equipment, services and respective overhead, profit, taxes, disbursements and related charges, and shall represent the actual addition or credit to the Contract Price.

4.01 **OPTIONS**

- A. **Goal Package**
 - 1 set of strung standard inline hockey goals.
The goals shall be constructed with 2-3/8" tubular steel and painted. Goals shall be 4' high x 6' wide fully welded with lacing loops. This will be supplied with 565 lb. Nylon knotless net with 1-1/2" mesh. Goals are fully strung with no assembly required.
- B. **Anodized Frames & Supports**
 - Provide clear anodized finish on aluminum frames. All aluminum shall be clear anodized finish, Aluminum Association designation AA M12C22A31 0.0002 in. minimum coating thickness.
- C. **Stainless Steel Gate Hardware**
 - Provide stainless steel gate latches and hinges in lieu of zinc plated.

END OF SECTION

ANSI D (2 x 34) Plotted by: david.leung Date: May 30, 2019 - 11:17 am File: H:\Proj\WSP 2019\19-05-680-00_Cavendish Hockey Rink\0.0 Drawings\5.1 Production Drawings\5.1 C1.1 Removals Layout_C1.1 Removals.dwg

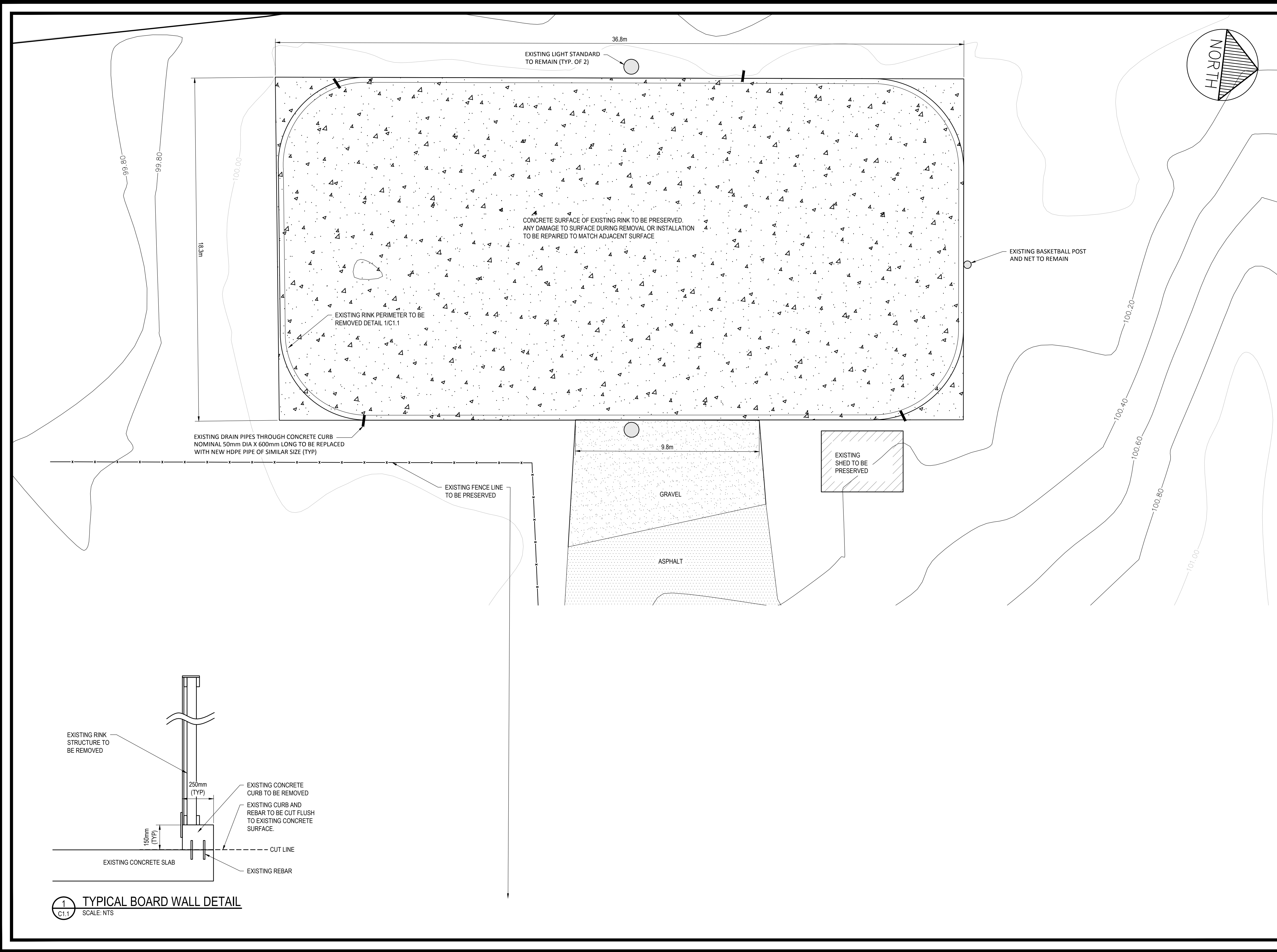

1
C1.1 TYPICAL BOARD WALL DETAIL
SCALE: NTS

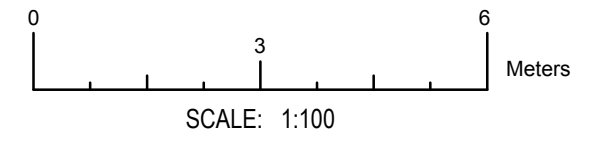
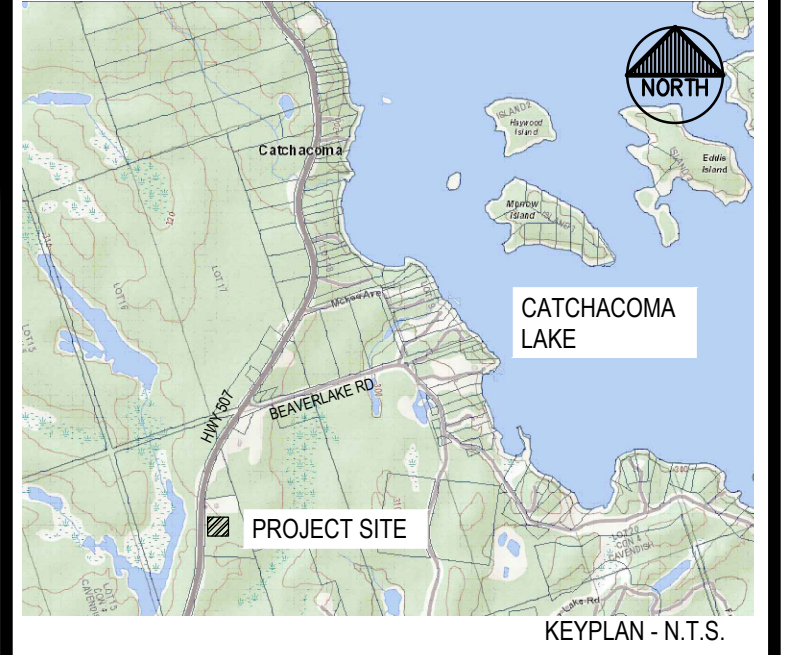
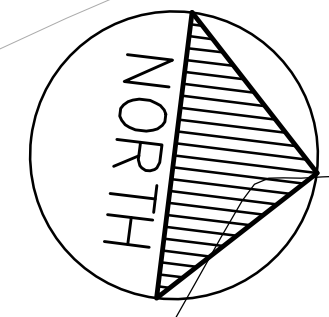

A ISSUED FOR TENDER		05-30-2019
No.	REVISION	DATE (MM-DD-YYYY)
STAMP:		DRAWN BY: BL
		DESIGNED BY: DL
		APPROVED BY: SJC
		DATE: MAY 30, 2019

wsp 294 RINK STREET, SUITE 103
PETERBOROUGH, ON
K9J 2K2
1-705-743-6850
wsp.com

PROJECT NAME:
CAVENDISH HOCKEY RINK

DRAWING NAME:
EXISTING CONDITIONS AND REMOVALS PLAN

CLIENT:
**MUNICIPALITY OF TRENT LAKES
760 PETERBOROUGH CR 36
TRENT LAKES, ON. KOM 1A0**

PROJECT No.: 171-16828-00	DWG. No.: C1.1	SHEET NUMBER: 1 OF 2	REVISION: A
---------------------------	----------------	----------------------	-------------

ANSI D (2 x 34) Plotted by: daveid.leving Date: May 30, 2019 - 12:00 pm File: H:\Proj\WSP 2019\19-05480\00_Cavendish Hockey Rink\A1.0 Drawings\5.5 Current Drawings\5.5.1 Production Drawings\191-05480-00_CAVENDISH RINK.dwg Layout: C1.2 SITE PLAN

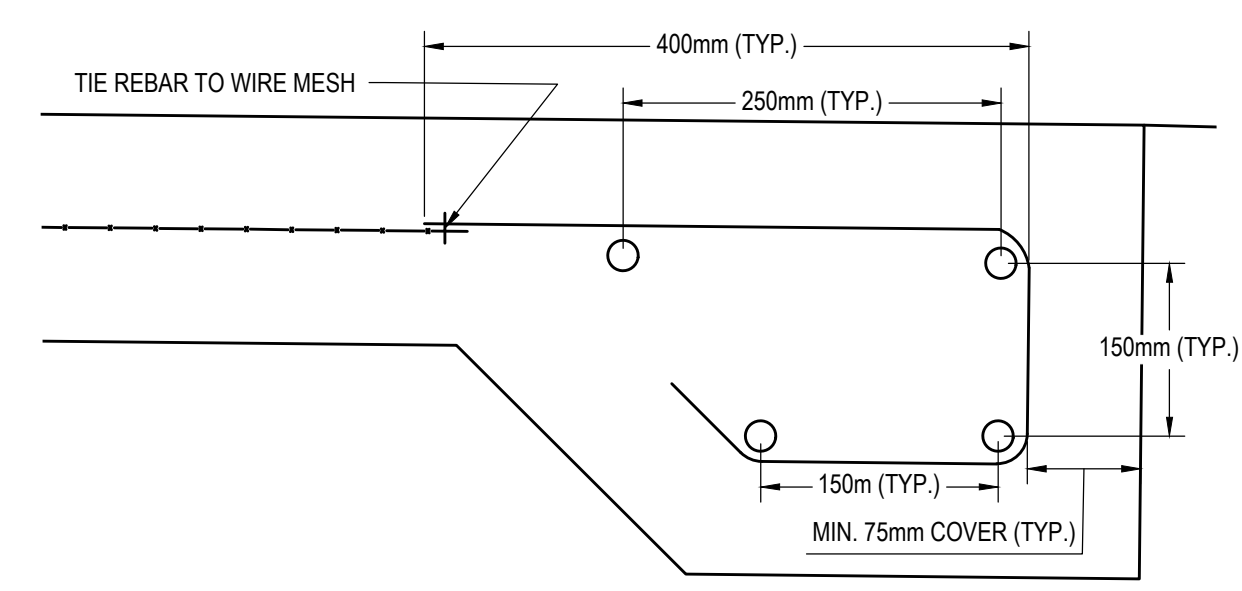
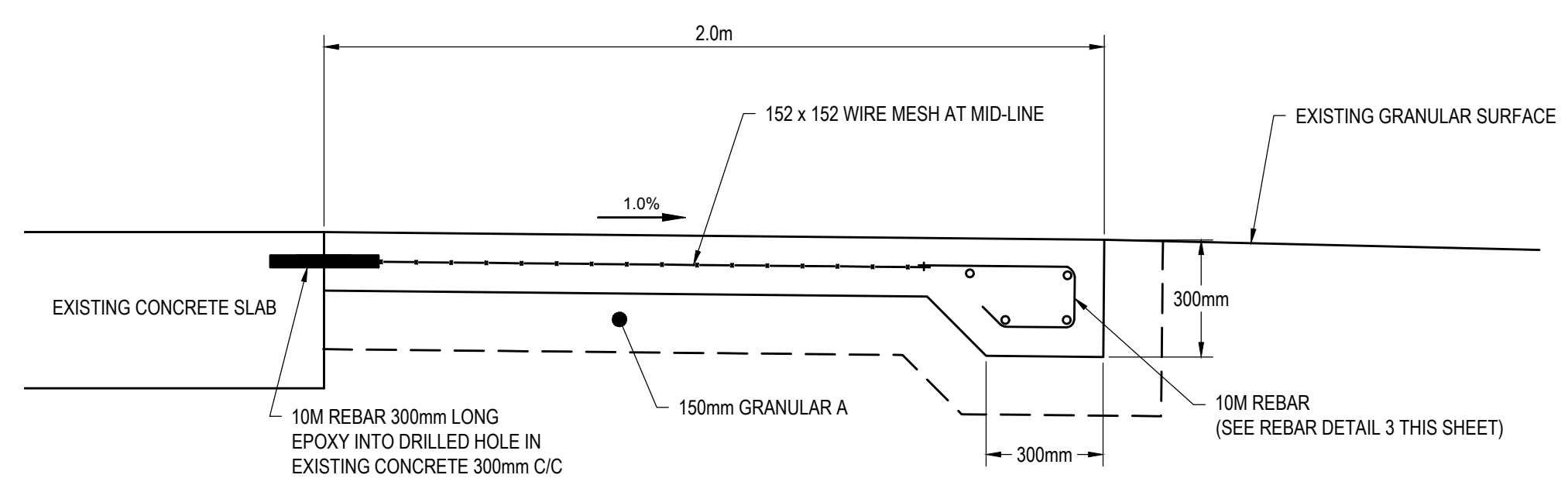
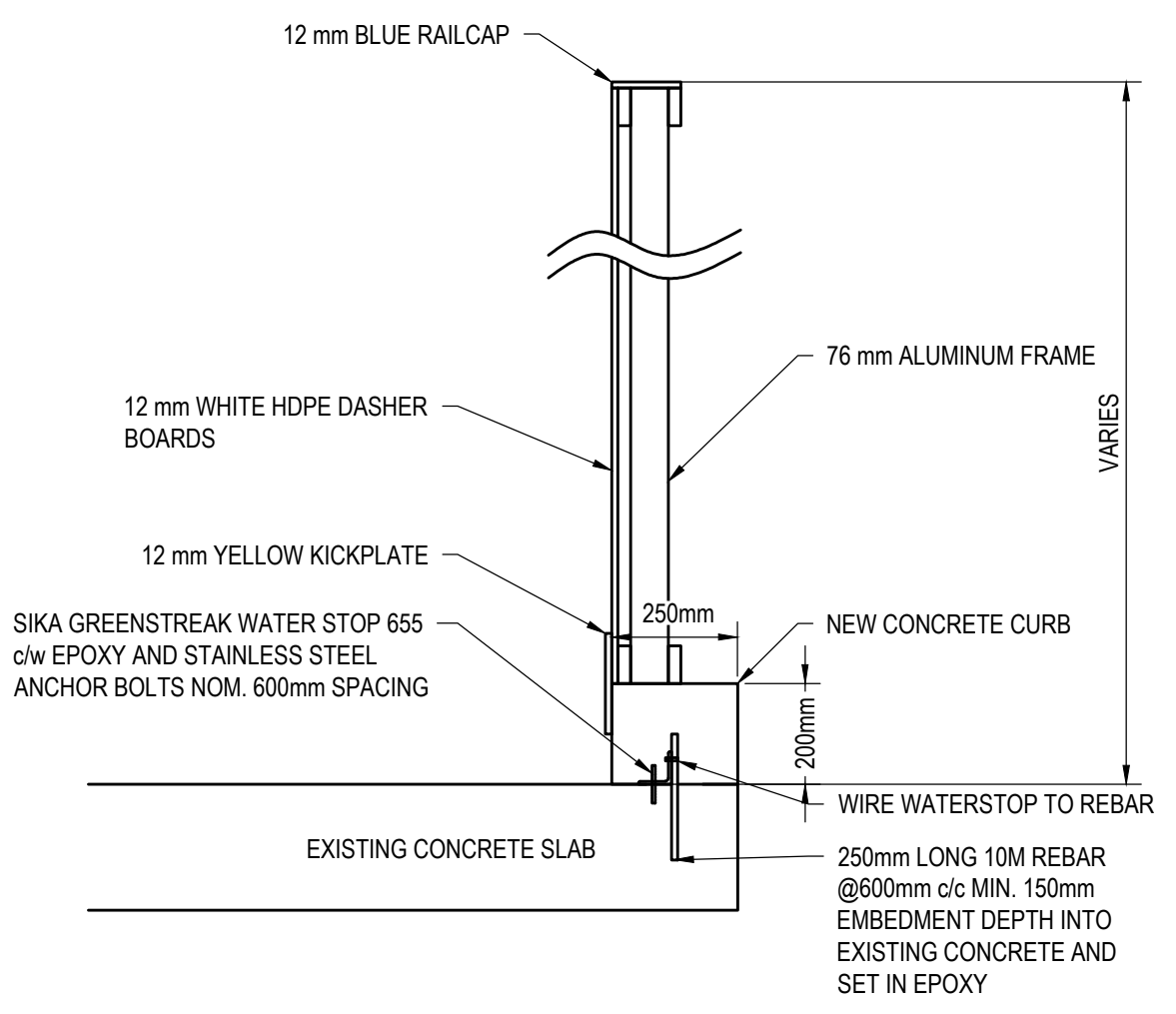
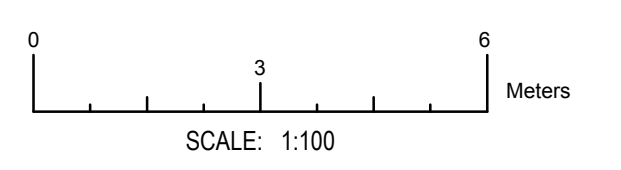
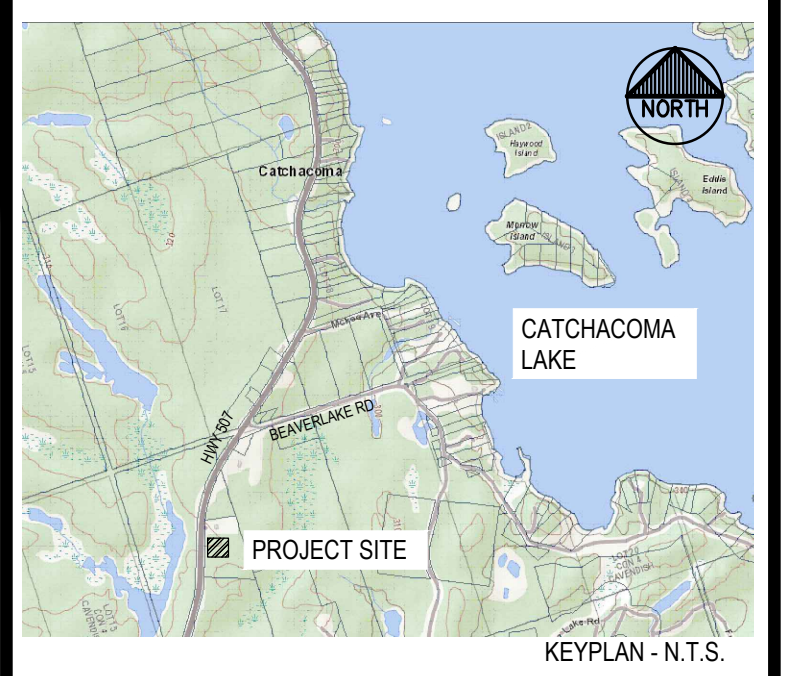
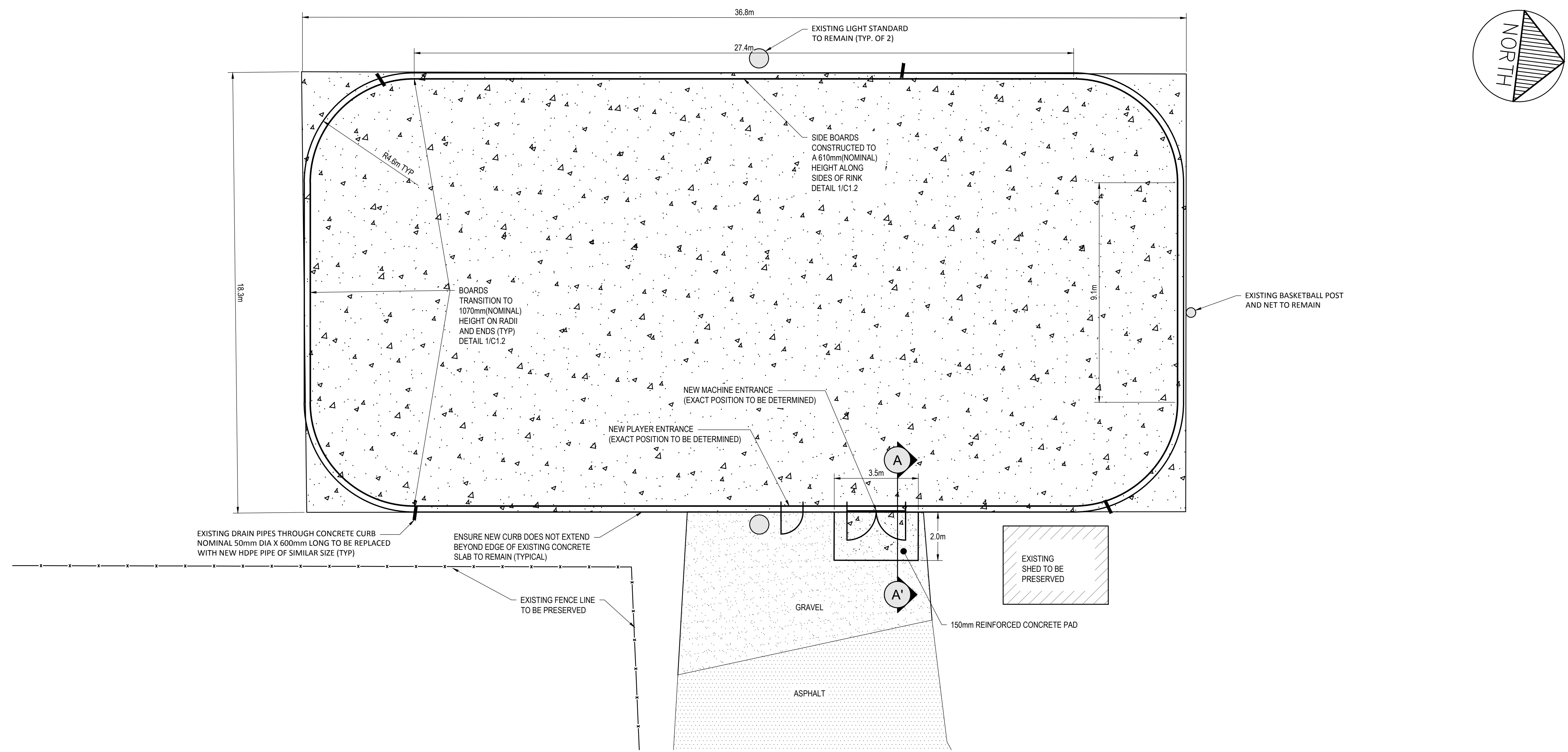

A ISSUED FOR TENDER		05-30-2019
No.	REVISION	DATE (MM-DD-YYYY)
STAMP:		DRAWN BY: BL
		DESIGNED BY: DL
		APPROVED BY: SJC
		DATE: MAY 30, 2019

wsp 294 RINK STREET, SUITE 103
PETERBOROUGH, ON
K9J 2K2
1-705-743-6850
wsp.com

PROJECT NAME:
CAVENDISH HOCKEY RINK

DRAWING NAME:
PROPOSED NEW CONSTRUCTION

CLIENT:
**MUNICIPALITY OF TRENT LAKES
760 PETERBOROUGH CR 36
TRENT LAKES, ON. KOM 1A0**

PROJECT No.:	DWG. No.:	SHEET NUMBER:	REVISION:
191-05480-00	C1.2	2 OF 2	A