



Trailer Park Guide

The Municipality of Trent Lakes
Building and Planning Department
760 Peterborough County Road 36
Trent Lakes, ON K0M 1A0
705-738-3800

Submit your permit online at <https://ca.cloudpermit.ca> or visit www.trentlakes.ca

TRAILER PARK GUIDE

This guide is for informational purposes only. It is the responsibility of the Applicant/Designer to review the building code to ensure all information is complete, accurate, and up to date.

Recreational Vehicle – Self Propelled



Recreational Vehicle – Towed



Park Model Trailer



Manufactured Home



DEFINITIONS

Recreational Vehicle (*Travel Trailer, Tourist Trailer, Camper, or Motorhome*) means is a vehicle that is either self-propelled or towed by another vehicle and meets the following criteria:

- a) It is built on a single chassis mounted on wheels;
- b) It is designed to facilitate relocation;
- c) It contains sleeping accommodations and may include self-contained fixtures and appliances; and
- d) It has a width less than 2.6m in the transit mode.

Recreational Vehicles are governed by 'CSA Z240 RV Series' and Transport Canada – 'Motor Vehicle Safety Regulation'. They are designed for operation on highways without special permits.

Park Model Trailer means a recreational unit that meets the following criteria:

- a) It is built on a single chassis mounted on wheels;
- b) It is designed to facilitate relocation from time to time;
- c) It is designed as living quarters for seasonal camping and may be connected to those utilities necessary for operation of installed fixtures and appliances; and
- d) It has a gross floor area, including lofts, not exceeding 50m² when in the set-up mode, and has a width greater than 2.6m in the transit mode.

Park Model Trailers are governed by 'CSA Z241' and the Ontario Building Code. They generally require special permits for highway operation.

Manufactured Home (*Factory-Built Home, Modular Home*) means a dwelling that is constructed in a factory in one or multiple sections to be transported to the permanent site where final assembly occurs. Manufactured Homes are governed by 'CSA A277', 'CSA Z240 MH Series' and the Ontario Building Code. They are not self-contained and are designed for year-round use.

Self-contained means the unit has plumbing, electrical, and/or mechanical systems which are capable of operating for a limited period of time without connection to exterior systems.

Deck is a raised uncovered platform that is either freestanding or attached to another structure.

Patio means a concrete or stone platform constructed at grade level and is not attached to another structure.

Porch (*Sunroom, Screened-Room, Florida Room*) means an unheated covered structure that includes a deck/patio and a roof. A porch may or may not include walls.

PERMIT REQUIREMENTS AND RESTRICTIONS

Zoning

Trailer Parks throughout the Municipality of Trent Lakes are subject to our Comprehensive Zoning By-law B2014-070 as amended. The Parks are zoned as Tourist Commercial – 1, which will apply to each and every site within their respected park.

Each Site shall maintain the following:

Maximum site coverage = **24%**
Minimum front yard depth = 6 Metres
Minimum side & rear yard depth = 3 Metres
Minimum distance from water = 61 Metres

One trailer shall be permitted per site

Permit Submission

To submit a permit, you will require the following items and is not limited to:

Building Permit Application
Site plan (see page 9 for details on how to compose a site plan)
Architectural Drawings
Park Authorization
Pre-Engineered Accessory Add-a-Rooms will require the appropriate engineered documentation.

Park Model Trailers will require the trailer details such as make, model, and CSA #. Anchorage requirements, which can be found further in the guide.

Development charges will apply to new Park Model Trailers if there was not a previous park model trailer on trailer site. As of April 2, 2026, the fee is \$3,667.

The design and construction of any building must conform to the requirements of the current amended version of the Ontario Building Code as well as all other applicable by-laws. This guide applies to Tourist Commercial Zones (Licensed Trailer Parks). Additional requirements/restrictions apply outside of these areas.

Trailer Parks Sites are not permitted to contain permanent structures, except for common facilities. Therefore all vehicles and structures placed on a site must either be mobile or placed on above grade footings only. No modifications are permitted that would restrict the mobility of a trailer as outlined below.

Recreational Vehicles:

Building Permits are not required to setup or move a recreational vehicle. Recreational vehicles must be maintained and licensed in accordance with Ministry of Transportation Ontario (MTO) and Transport Canada (TC) requirements. Recreational vehicles are required to remain mobile at all times and are therefore not permitted to be structurally modified or have any accessory structures added.

Park Model Trailers:

Building Permits are required for the installation of all park model trailers. Although some components can be removed and stored (such as towing frame and tires), Park model trailers must remain capable of being moved from time to time. Park Model Trailers are permitted to have accessory structures, however they must be structurally independent to permit the trailer to be moved without damaging the trailer or accessory structure. Park Model Trailers are not designed to support the weight of another structure and structural modifications can void the manufacturer's warranty.

Manufactured Homes:

Manufactured Homes require a permanent foundation and are therefore not permitted in any Tourist Commercial Zone (Trailer Park).

Accessory Structures:

Accessory Structures including Decks, Porches, Sun Rooms, Storage Sheds, etc. require a Building Permit and are permitted to be constructed with a Park Model Trailer. Accessory Structures must conform to the Comprehensive Zoning By-law and generally must not exceed 10' in width and the length of the associated trailer.

GENERAL INFORMATION

LETTER OF AUTHORIZATION

Under most circumstances the owners/managers of a Trailer Park are the legal owner of the property. Therefore they must give the representative from the individual trailer site authorization to apply for a building permit.

Sample Authorization Letter

Pineway Campground
159 Some Road
Buckhorn, ON
K0L 1J0



April 1, 2011

Municipality of Trent Lakes
760 Peterborough County Road 36
Trent Lakes, ON
K0M 1A0

Re: Building Permit Application for construction of a deck at Site 6 (6 Pine Lane) at Pineway Campground

We have reviewed the proposal for a deck at Site 6 in the park and have no objections. Bill and Jane Smith are authorized to apply for this permit on behalf of the park.

Should you have any questions, please contact us at 705-555-5555.

Sincerely,

Sally Jones
Property Manager
Pineway Campground

PARKING

Parking for each site shall be maintained in accordance with the Municipal requirements.

ADDRESSING

Each site shall be identified in accordance with the addressing by-law.

DESIGN INFORMATION

ACCEPTABLE FOUNDATION SYSTEMS FOR TRAILER PARKS

Foundation systems for decks and structures in trailer parks are typically the following situations:

- (a) A deck constructed with distance from grade to underside of the floor joists **is not more than 24"**
- (b) A deck constructed with the distance from grade to the underside of the floor joists **exceeds 24"**
- (c) An existing deck where the owner wishes to construct additional living space (add-a-room)
- (d) A new deck and add-a-room construction proposal

Division B- Part 9, Sentence 9.12.2.2 (7) of the OBC states that foundation depths required in Sentence (1) do not apply to foundations for decks and other accessible exterior platforms,

- (a) That are not more than 1 storey,
- (b) That are not more than 55 square meters (592 sf) in building area,
- (c) Where the distance from the finished ground to the underside of the floor joists is not more than 600 mm (24"),
- (d) That are not supporting a roof, and
- (e) That are not attached to another structure, unless it can be demonstrated that differential movement will not adversely affect the performance of that structure.

The Building Department has determined that based on the above section of the Ontario Building Code, the following foundation systems will be required. The process for making the determination on what would be required for floating decks including decks supporting roof loads included:

1. The decks, add-a-rooms, trailers and park models are all floating structures and as such must have similar foundations.
2. Distance above grade becomes an element of consideration due to uplift from high winds
3. We seem to experience more frequent weather events due to climate change
4. Safety is always the factor for any Code related decisions.

Foundation Systems

- (a) A deck constructed with distance from grade to underside of the floor joists is not more than 24"

For a typical deck that complies with all the exceptions of 9.12.2.2 (7), and specifically where the distance from the grade to the underside of the floor joist is not more than 24", a 6x6 post secured into 6 inch deck block placed a minimum 24" x 24" x 3.5 " pad (precast or poured). The pad is to be located on bed of crushed stone or screenings with all organics removed.

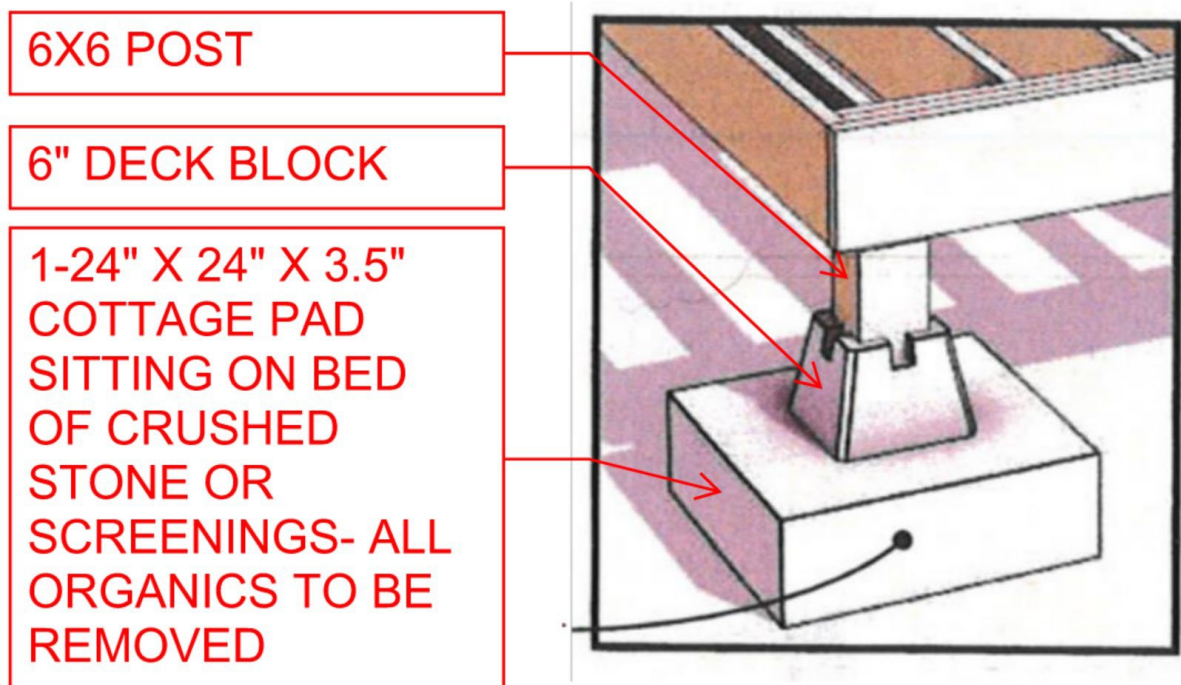

For all other scenarios other than option (a)

- (b) A deck constructed with the distance from grade to the underside of the floor joists exceeds 24"
- (c) An existing deck where the owner wishes to construct additional living space (add-a-room)
- (d) A new deck and add-a-room construction proposal

6 x 6 wood posts will be required to be secured to 2 – 24" x 24" x 3.5" pads epoxied together with a 6 inch saddle epoxied into the two stacked pads.

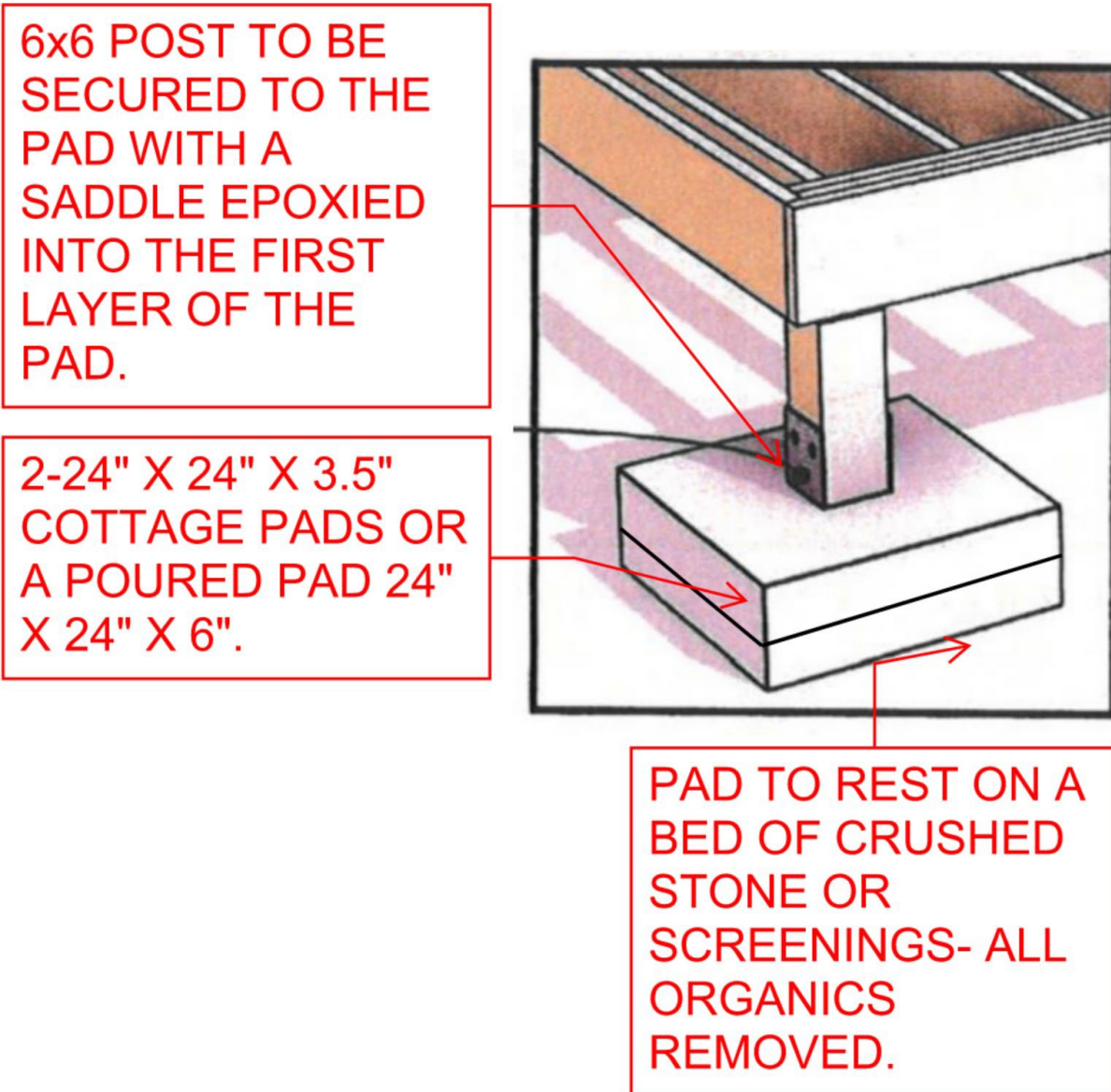

EXAMPLE DECK DRAWING

-THESE EXAMPLE DRAWINGS CONTAIN THE MINIMUM REQUIRED INFORMATION FOR BUILDING PERMIT SUBMISSION.

-THESE DRAWINGS ARE AN EXAMPLE ONLY AND ALL SUBMISSIONS MUST CONFORM TO THE CURRENT VERSION OF THE ONTARIO BUILDING CODE.

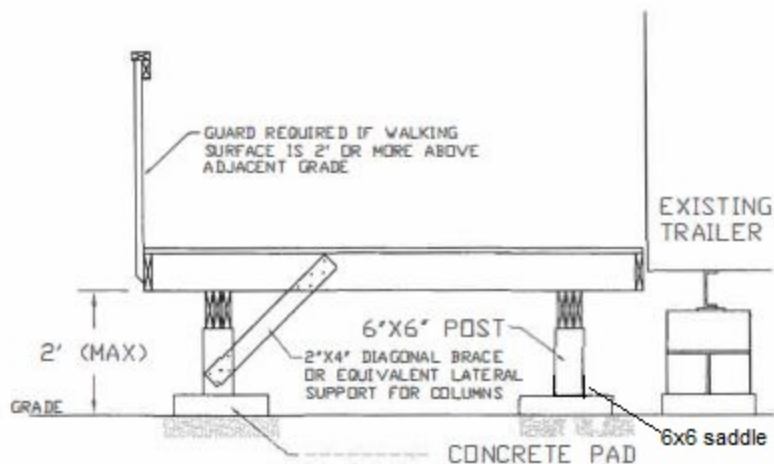

RAISED DECK DETAIL

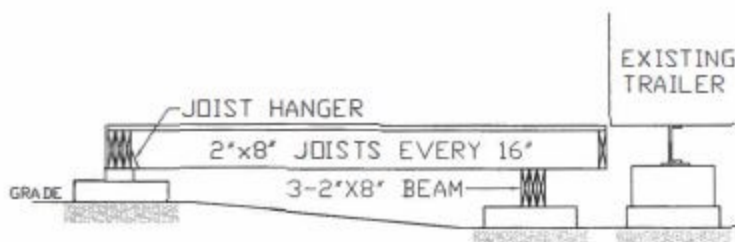

LOW DECK DETAIL

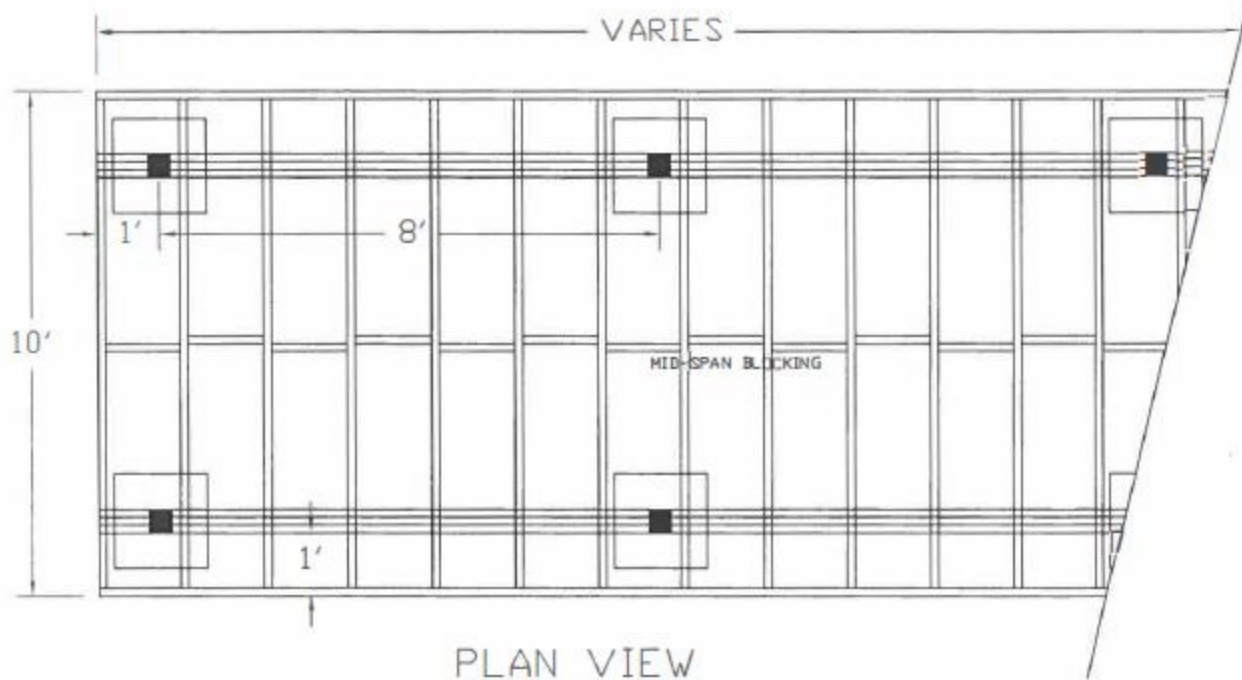

PLAN VIEW

DECKING

Requirements: Table 9.23.14.5.A., 9.23.3.5.(1)

- Decking less than or equal to 184mm (7-1/4") wide shall be fastened with two 51mm (2") common/spiral nails or two 45mm (1-3/4") Screws at each support.
- Decking shall consist of solid lumber at least 17.0mm (11/16") thick when joists are spaced 400mm (16") or less and at least 19.0mm (3/4") when joists are spaced more than 400mm (16").

FASTENERS

- All fasteners used must be properly treated/coated to prevent corrosion.
- Equivalent screws may be used in lieu of nails

STAIRS

Stairs shall conform to Section 9.8 of the Ontario Building Code

RAILING

Railings shall conform to Section 9.8 and Supplementary Standard SB-7 of the Ontario Building Code (see attached) or a pre-engineered system certified by an Ontario Engineer and installed in conformance with the manufacturer's instructions.

SPACIAL SEPARATION

Park Model Trailers shall comply with Section 9.10 regarding distance between units.

ABOVE GRADE ELECTRICAL CONDUCTORS

Structures must maintain a minimum distance from above grade electrical conductors in accordance with Article 3.1.19.1 of the OBC.

MANUFACTURING STANDARDS

Park Model Trailers shall be manufactured and labeled in accordance with CAN/CSA-Z241 Series, "Park Model Trailers". Units not manufactured to Canadian standards must be certified prior to use.

Site plans

Site plans are to be drawn to scale and must clearly show the following:

- Lot size
- Location of the existing structures and distances to the site lot lines
- Dimensions of existing and proposed structures
- Road name
- Lot number
- Over-head hydro lines to be shown.
- Distance from the unit to the adjacent unit on each side of the lot.

EXAMPLE SITE PLAN

Maximum Lot Coverage = 24%

To Calculate your lot coverage,
multiply your depth x width, multiply
that number by .24 for max lot cov.

Multiply existing structures L x W &
proposed to achieve proposed lot
coverage

LANEWAY

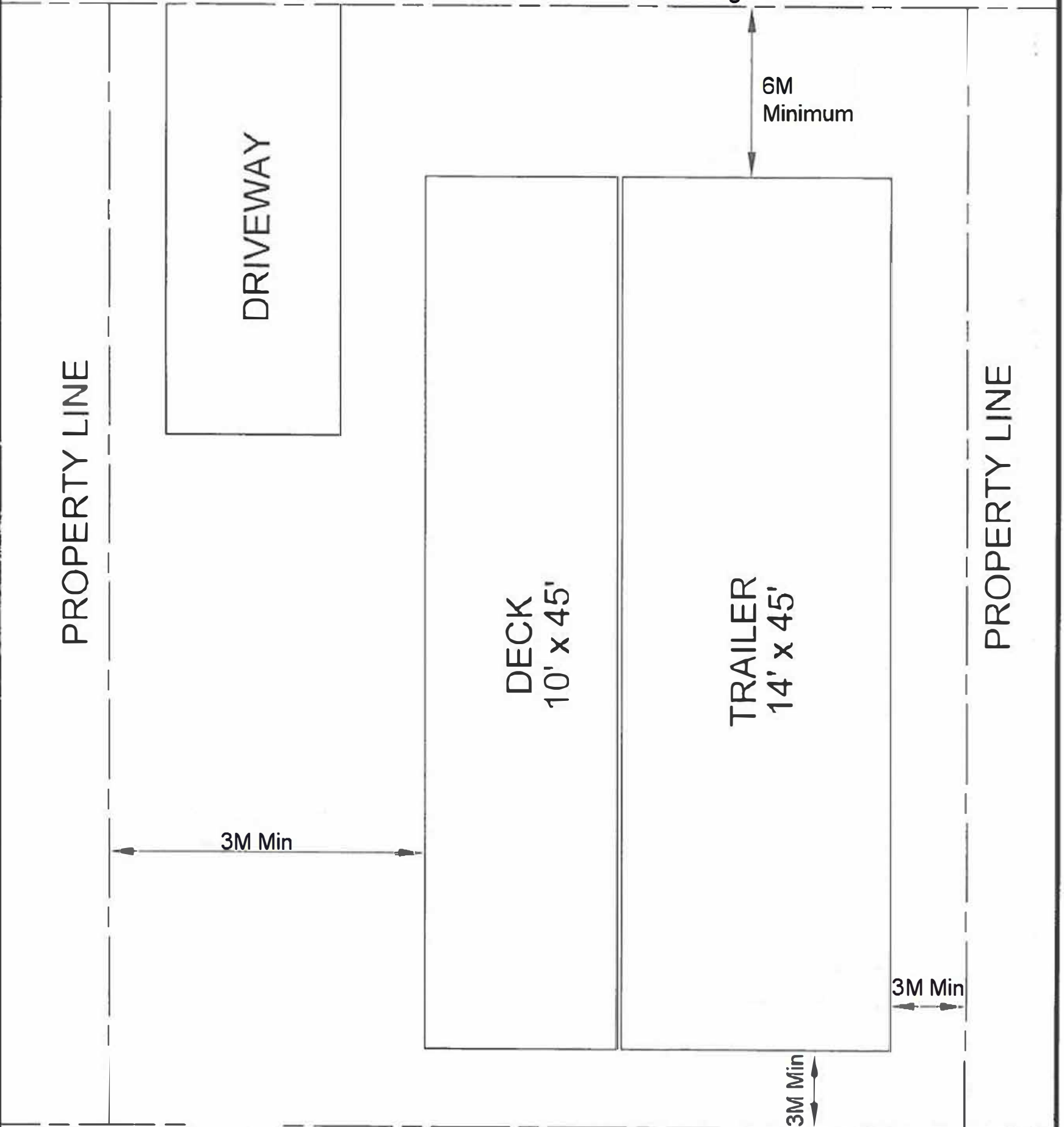

ANCHORAGE

Anchorage: 9.38.3.3.(1), 9.23.6.2.(1), & 9.23.6.3.(1)

Park Model Trailers shall be anchored in conformance with CSA Z240.10.1 or the manufacturer's installation instructions. Individual components shall be directly fastened to their supporting and supported members to resist uplift.

Exemption: 9.23.6.2.

Decks are not required to be anchored, as noted above, where the following criteria are met:

- (a) are not more than 1 *storey*,
- (b) are not more than 55 m² in area,
- (c) do not support a roof, and
- (d) are not attached to another structure, unless it can be demonstrated that differential movement will not adversely affect the performance of that structure.

Anchors and components shall meet the following requirements unless otherwise designed:

- installed at a maximum spacing of 7.3 m (24')
- attached directly to the frame of the park model trailer
- have a minimum rated capacity of 17.8 kN (4000 lb)
- tightened to limit cable slack to no more than 50 mm (2")

Anchorage systems not specified above shall be designed to resist uplift and overturning under the 1/50 hourly design wind pressure (Trent Lakes = 0.34 kPa).

ANCHORAGE OF PARK MODEL TRAILERS

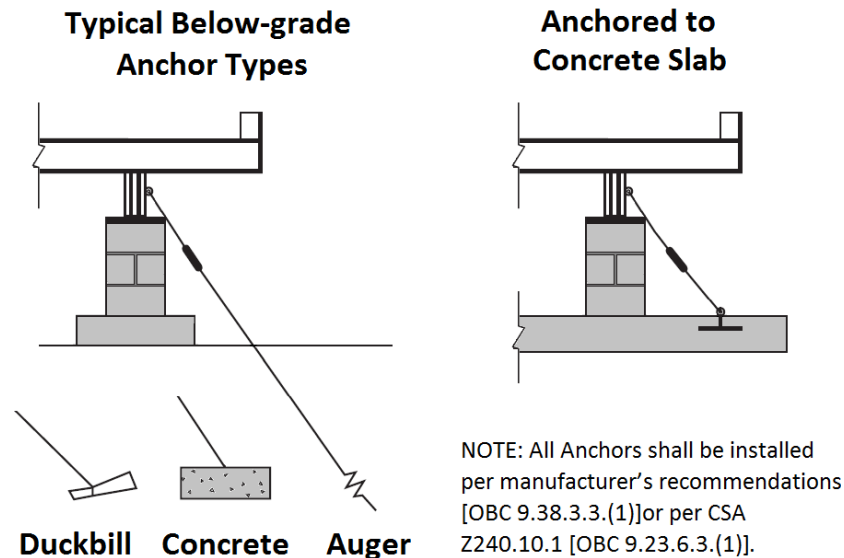

BEAMS

9.23.4.2.(3) Table A-8

Supported Length (m) (1)	Maximum Span (m)		
	3-38x184 (3-2"x8")	3-38x235 (3-2"x10")	3-38x286 (3-2"x12")
2.40 (7.87')	3.07 (10'-0")	3.92 (12'-10")	4.57 (14'-11")
3.00 (9.84')	2.85 (9'-4")	3.52 (11'-6")	4.09 (13'-5")
3.60 (11.8')	2.63 (8'-7")	3.22 (10'-6")	3.73 (12'-2")
4.20 (13.7')	2.44 (8'-0")	2.98 (9'-9")	3.46 (11'-4")

(1) Supported length means half the sum of the joists spans on both sides of the beam.

*Spruce-Pine-Fir No.1 or No.2 Grade

Bearing: 9.17.4.1. & 9.23.8.1.

-Beams shall have a bearing surface on each of their supporting member of not less than their width and not less than 89 (3.5") in length.

Built-up wood: 9.23.8.3.

-Built up beams shall be nailed together with a double row of nails not less than 89 (3.5") in length, not more than 450 (18") apart, and not more than 100 (4") from the end.

JOISTS

Size & Spacing: 9.23.4.2.(1) & Table A-1

Joist Size	Maximum Span (m)		
	300 (12") o.c.	400 (16") o.c.	600 (24") o.c.
38x140 (2"x6")	3.14 (10'-3")	2.85 (9'-4")	2.49 (8'-2")
38x184 (2"x8")	3.81 (12'-6")	3.58 (11'-9")	3.27 (10'-8")
38x235 (2"x10")	4.44 (14'-6")	4.17 (13'-8")	3.92 (12'-10")
38x286 (2"x12")	5.01 (16'-5")	4.71 (15'-5")	4.42 (14'-6")

*Spruce-Pine-Fir No.1 or No.2 Grade with Bridging

*The use of floor joists less than 38x184 (2"x8") is not recommended as it does not allow for the proper attachment of railings.

Cantilever: 9.23.9.9.

-38x184 (2"x8") may not be cantilevered more than 400 (16")

-38x235 (2"x10") or larger may not be cantilevered more than 600 (24")

Bearing: 9.23.9.1. – 9.23.9.3., 9.23.3.4.(1)

-Floor joists may be supported on the tops of beams or may be supported with proper metal joist hangers.

-The floor joists must be mechanically fastened to the supporting member with two 82 (3-1/4") nails.

Bridging: 9.23.9.4.(2), 9.23.3.4.(1)

-Bridging shall consist of 19 x 64 (1"x3") cross bridging, 38 x 38 (2"x2") cross bridging or solid blocking the same dimension as the supported floor joists.

-Bridging shall be located not more than 2100 (6'-11") from each support or other rows of bridging.

-Bridging shall be fastened with two 57 (2-1/4") nails at each end.

ILLUSTRATIONS

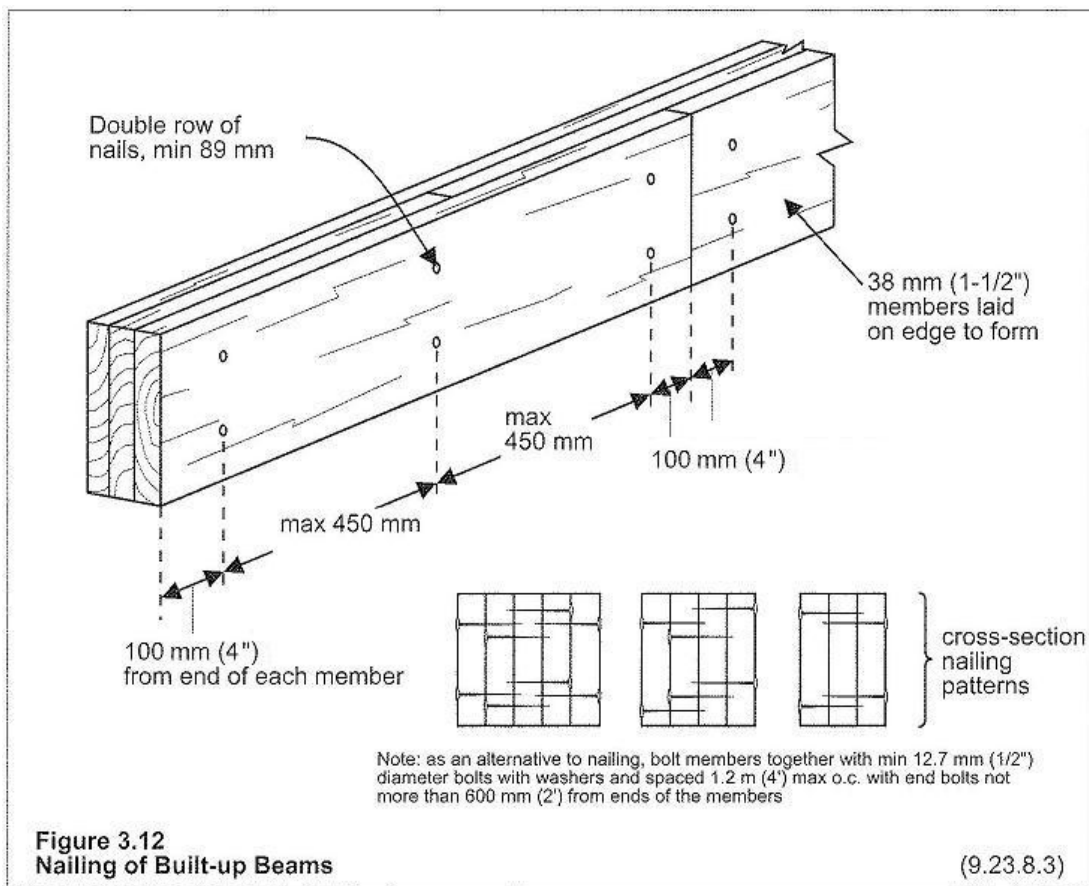
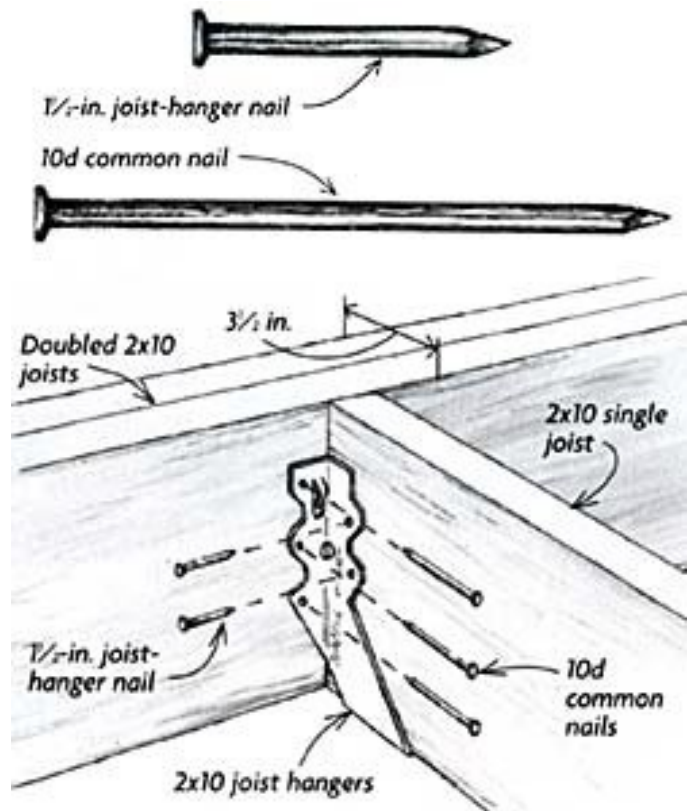
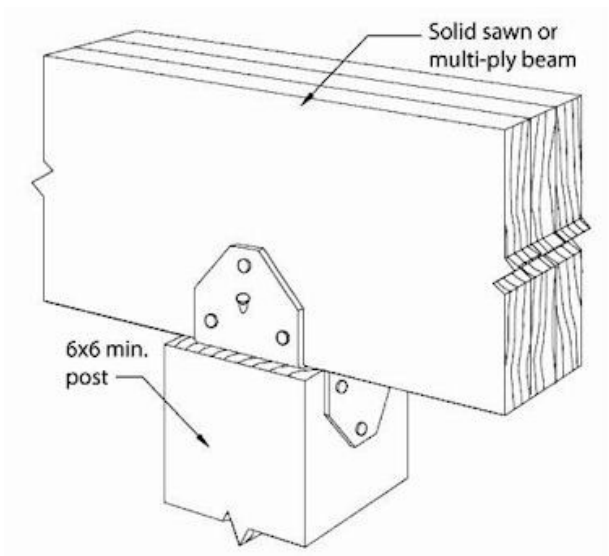
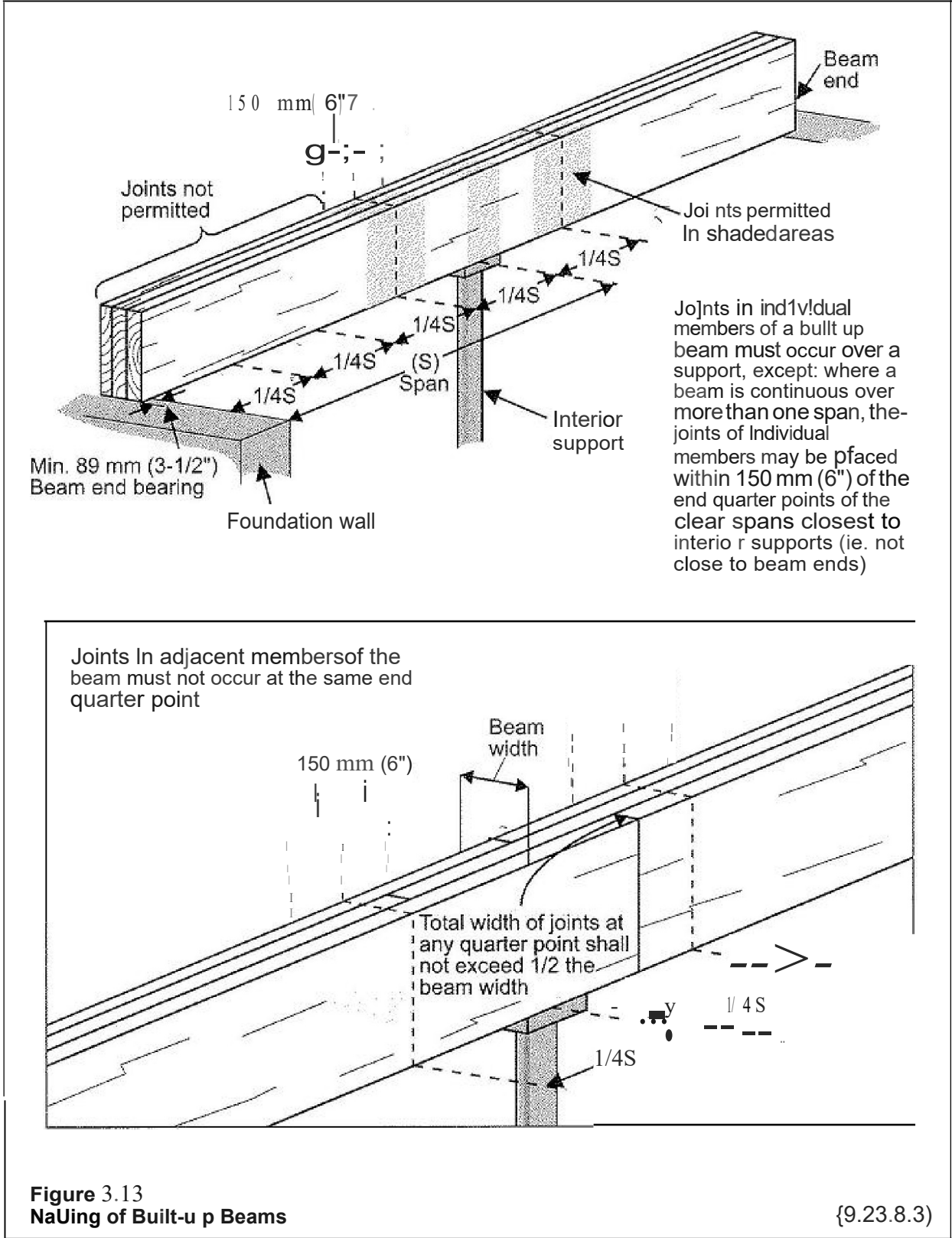
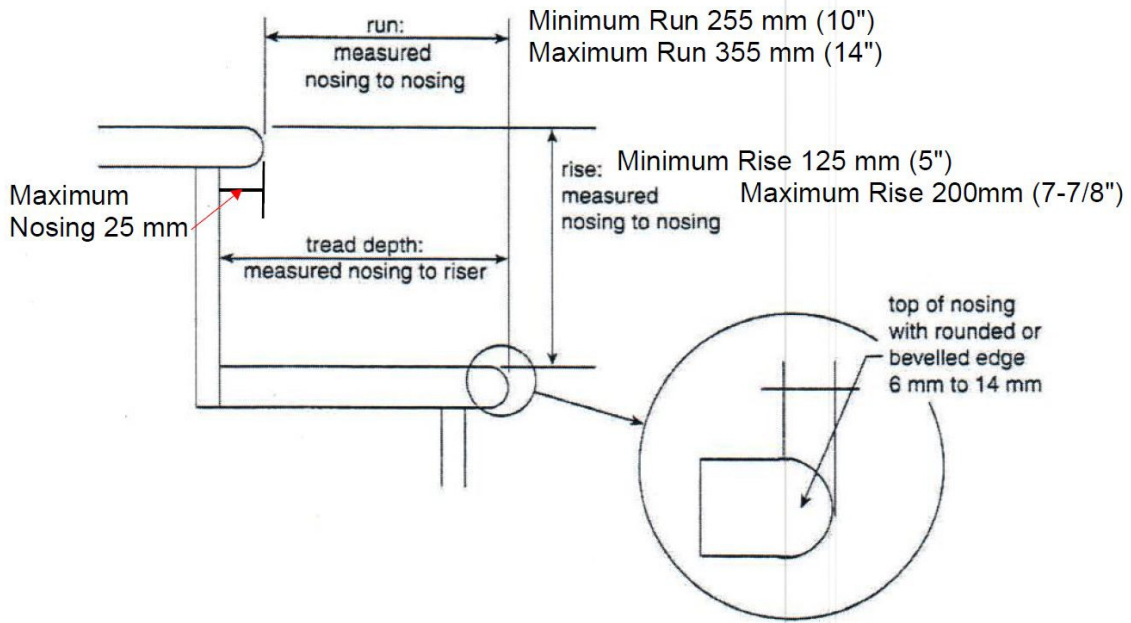

Figure 3.12
Nailing of Built-up Beams

(9.23.8.3)



Stair Detail



WOOD STAIRS

- W = max 900 mm (35") in dwelling units
- W = max 1200 mm (47") in dwelling units when risers support the front of the treads unless stringers and treads designed for wider spacing
- W = max 600 mm (23-1/2") in other than dwelling units

Tread thickness:

- A = min 25 mm (1") when risers support front of tread
- B = min 38 mm (1-1/2") when tread unsupported at front and distance between stringers is no greater than 750 mm (30")

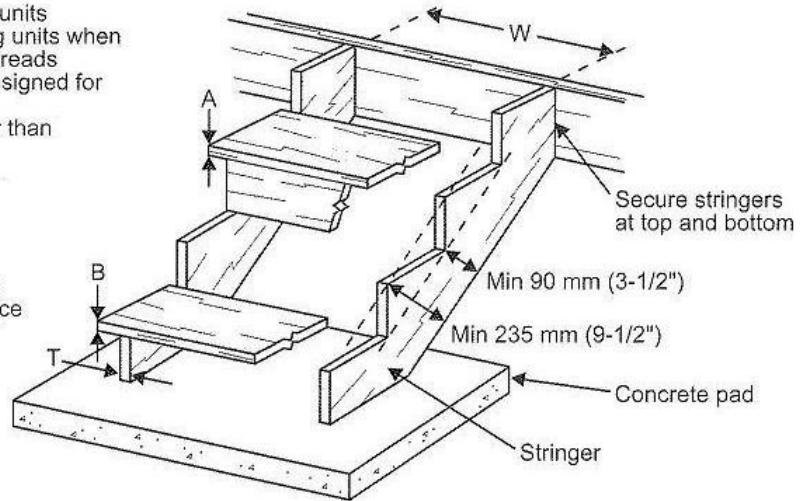
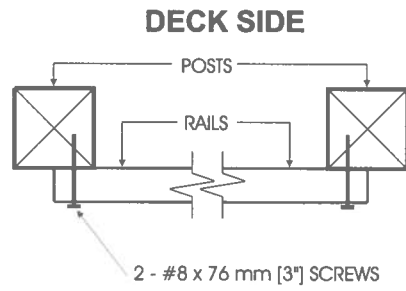

Table 2.2.1.
Exterior Post and Rail System Connection Details

Connection Detail	Detail Number	Description
Top Rail to Post and / or Bottom Rail to Post	EA-1	Top rail nailed to post
	EA-2	Top/bottom rail skew nailed to post with 76 mm (3") nails
	EA-3	Top/bottom rail skew nailed to post with 63 mm (2½") nails
	EA-4	Top/bottom rail face nailed or screwed to post
	EA-5	Top/bottom rail fastened to post with framing anchors
Post to Floor	EB-1	Post nailed to rim joist
	EB-2	Post screwed to rim joist
	EB-3	Post bolted to floor joist with 8 mm (⁵ / ₁₆ ") machine bolts
	EB-4	Post bolted to floor joist with 9.5 mm (³ / ₈ ") machine bolts
	EB-5	Post bolted to 2 floor joists
	EB-6	Post fastened to floor, where guard is parallel to floor joists
Infill Picket	EC-1	Picket nailed to endcap; endcap screwed to rail
	EC-2	Picket nailed to rail
	EC-3	Picket screwed to rail
	EC-4	Picket screwed to top rail and rim joist
Column 1	2	3

Table 2.2.2.
Exterior Cantilevered Picket System Connection Details

Connection Detail	Detail Number	Description
Cantilevered Picket (Douglas Fir-Larch, Spruce-Pine-Fir, Hem-Fir Species)	ED-1	Picket screwed to rim joist
	ED-2	Picket screwed to rim joist, where guard is parallel to floor joists
Cantilevered Picket (Northern Species)	ED-3	Picket screwed to rim joist and deck
	ED-4	Picket screwed to rim joist and deck, where guard is parallel to floor joists
Cantilevered Picket (Douglas Fir-Larch, Spruce-Pine-Fir, Hem-Fir Species, Northern Species)	ED-5	Corner
Column 1	2	3



PLAN

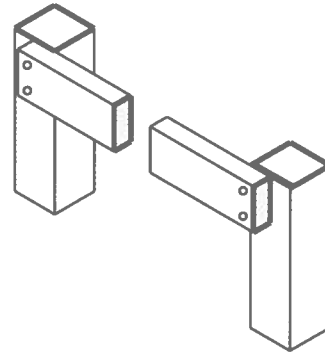

AXONOMETRIC

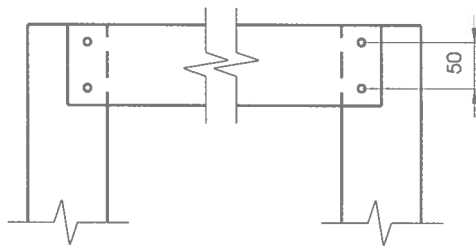

FRONT ELEVATION

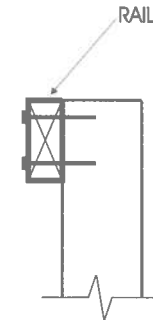

SIDE ELEVATION

Detail EA-4

Exterior Connection: Top/Bottom Rail Face Nailed or Screwed to Post

Notes:

1. If the rails are located on the deck side of the posts, 76 mm (3") nails may be used in place of the screws.
2. Where the top rail is continuous, the top rail may be fastened to each post with 3 - #8 x 76 mm (3") screws.
3. Dimensions shown are in mm unless otherwise specified.

MAXIMUM SPAN OF RAIL BETWEEN POSTS	
Species	Maximum Span, m (ft-in)
Douglas Fir-Larch, Hem-Fir, Spruce-Pine-Fir	1.77 (5'-10")
Northern Species	1.41 (4'-8")
Column 1	2

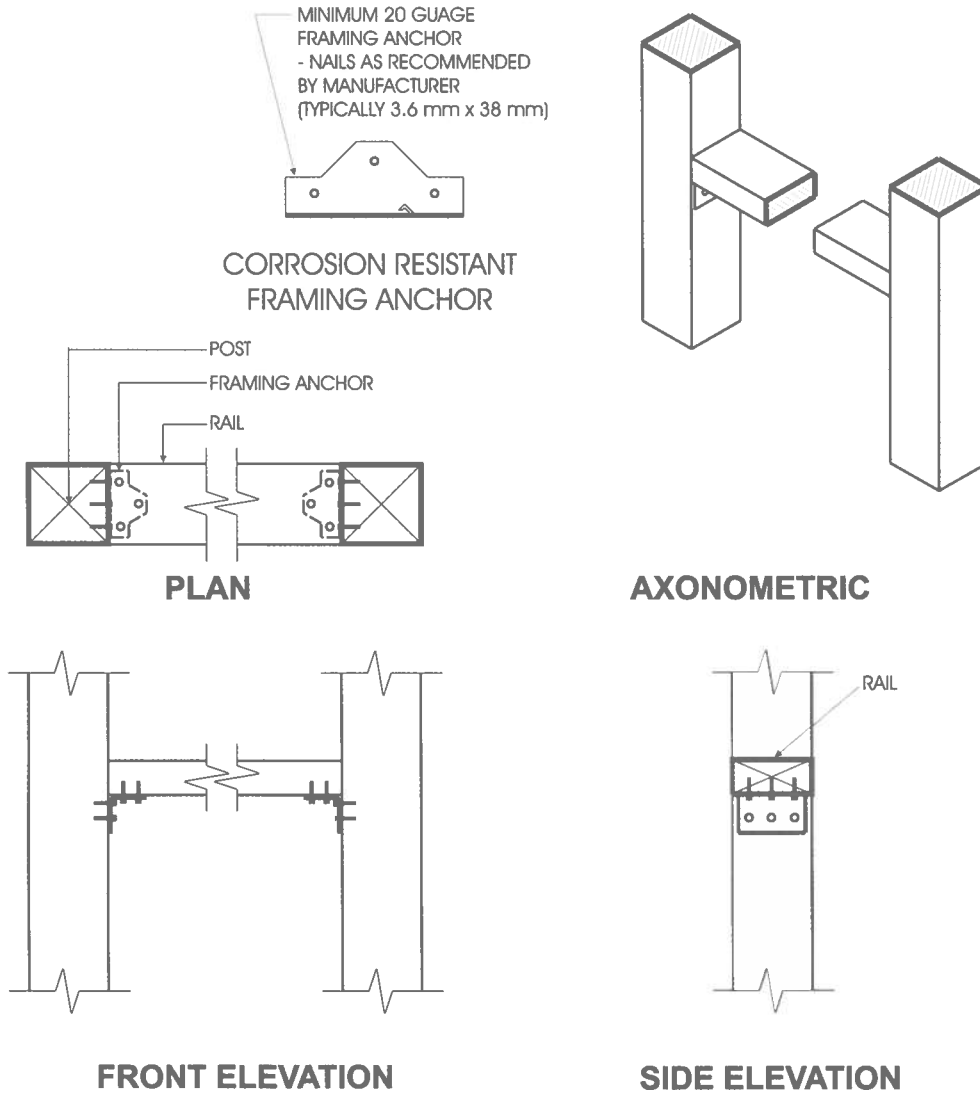

Detail EA-5

Exterior Connection: Top/Bottom Rail Fastened to Post with Framing Anchors

Notes:

1. Provide support to bottom rail at intervals not more than 2.0 m (6'-7").
2. The bottom rail may be bevelled as detailed in Figure 2.1.2.
3. Dimensions shown are in mm unless otherwise specified.

MAXIMUM SPAN OF RAIL BETWEEN POSTS	
Species	Maximum Span, m (ft-in)
Douglas Fir-Larch, Hem-Fir, Spruce-Pine-Fir	2.72 (8'-11")
Northern Species	2.18 (7'-2")
Column 1	2

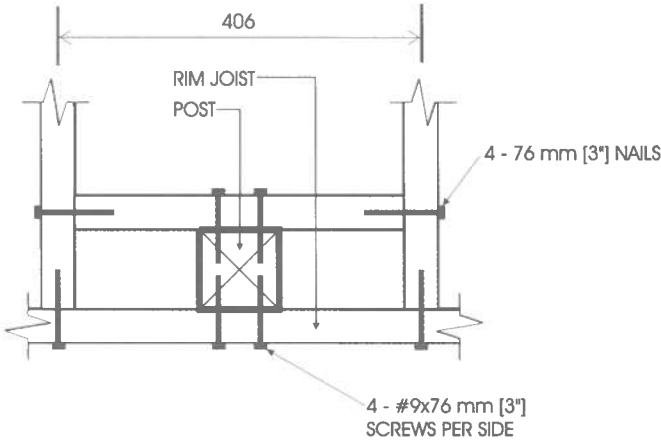

PLAN

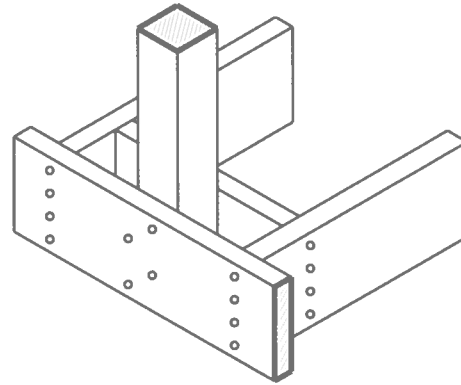

AXONOMETRIC

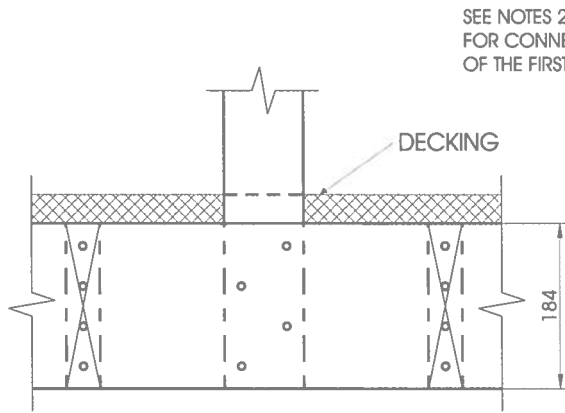

FRONT ELEVATION

SEE NOTES 2 & 3 FOR CONNECTION OF THE FIRST BOARD

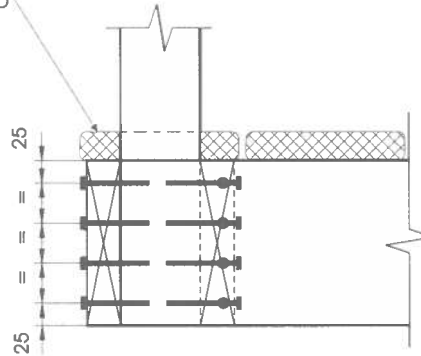

SIDE ELEVATION

Detail EB-2

Exterior Connection: Post Screwed to Rim Joist

Notes:

1. Decking is omitted from the plan view and the axonometric view for clarity.
2. Fasten 25 mm x 140 mm (5/4" x 6" nominal) outer deck board to rim joist with 63 mm (2 1/2") nails at 300 mm (12").
3. Fasten 25 mm x 140 mm (5/4" x 6" nominal) outer deck board to floor joist with 1 - 63 mm (2 1/2") nail at each joist.
4. The post may be positioned anywhere between the joists.
5. #9 screws may be replaced by #8 screws if the maximum spacing between posts is not more than 1.20 m (3'-11").
6. Dimensions shown are in mm unless otherwise specified.

MAXIMUM SPAN OF RAIL BETWEEN POSTS	
Species	Maximum Span, m (ft-in)
Douglas Fir-Larch, Hem-Fir, Spruce-Pine-Fir	1.56 (5'-1")
Northern Species	1.20 (3'-11")
Column 1	2

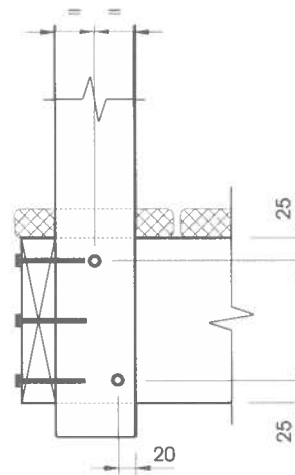
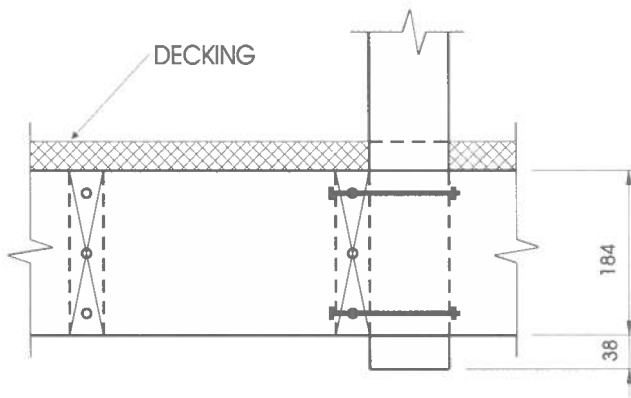
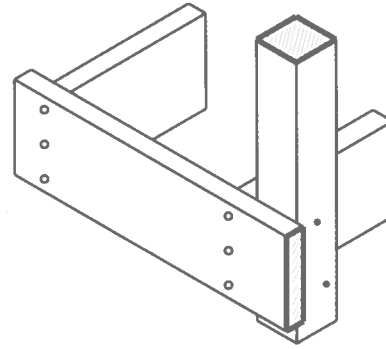
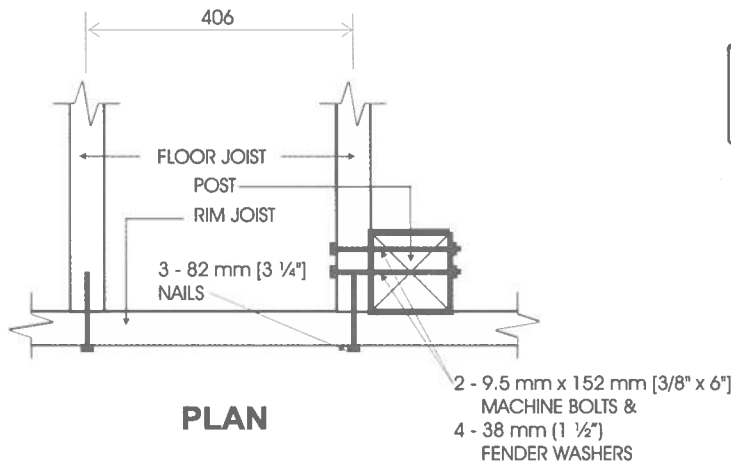

FRONT ELEVATION

SIDE ELEVATION

Detail EB-4

Exterior Connection: Post Bolted to Floor Joist - 9.5 mm (3/8") Bolts

Notes:

1. Decking is omitted from the plan view and the axonometric view for clarity.
2. 38 mm (1 1/2") post projection is not required where the maximum spacing between posts does not exceed 1.20 m (3'-11").
3. Joists may be spaced at 610 mm (24") o.c. or 406 mm (16") o.c.
4. Where floor joists are spaced at 610 mm (24") o.c., decking shall have a minimum thickness of 38 mm (1 1/2") and shall be fastened to the floor with 2 - 76 mm (3") nails.
5. Dimensions shown are in mm unless otherwise specified.

MAXIMUM SPACING BETWEEN POSTS	
Species	Maximum Span, m (ft-in)
Douglas Fir-Larch, Hem-Fir, Spruce-Pine-Fir	1.49 (4'-11")
Northern Species	1.20 (3'-11")
Column 1	2

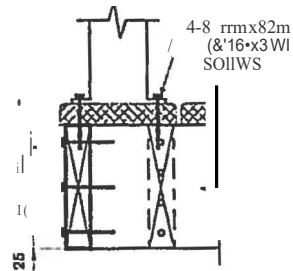
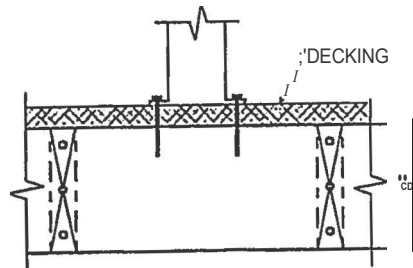
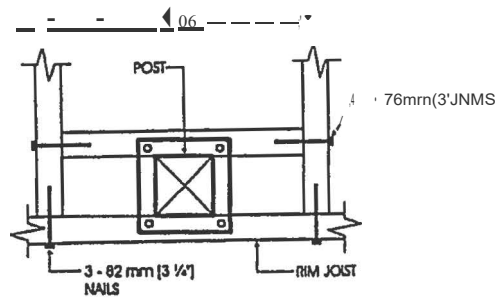
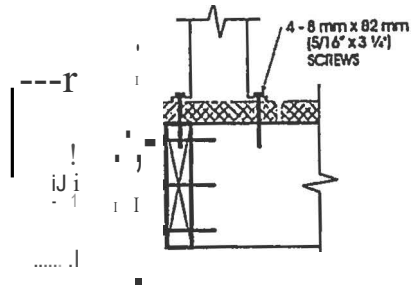
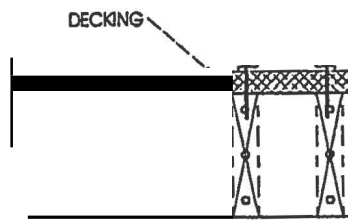
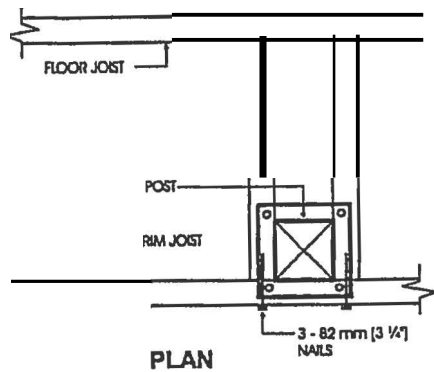

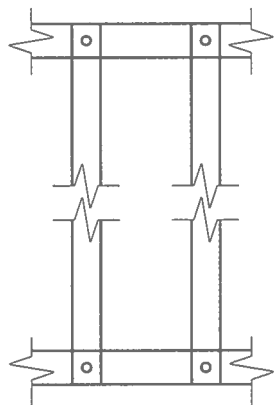
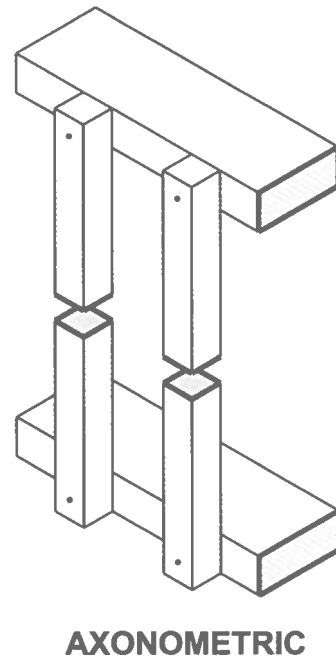
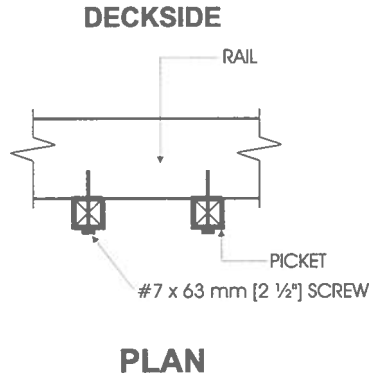

Detail EC-3

Exterior Connection: Infill Picket Screwed to Rail

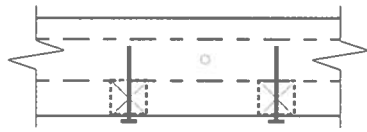

PLAN

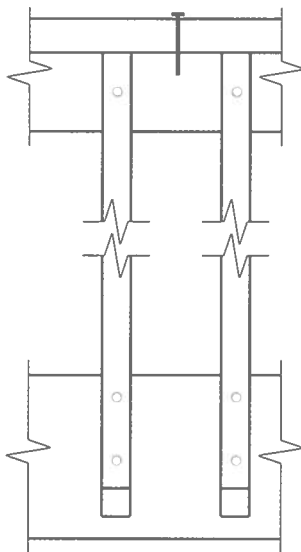

FRONT ELEVATION

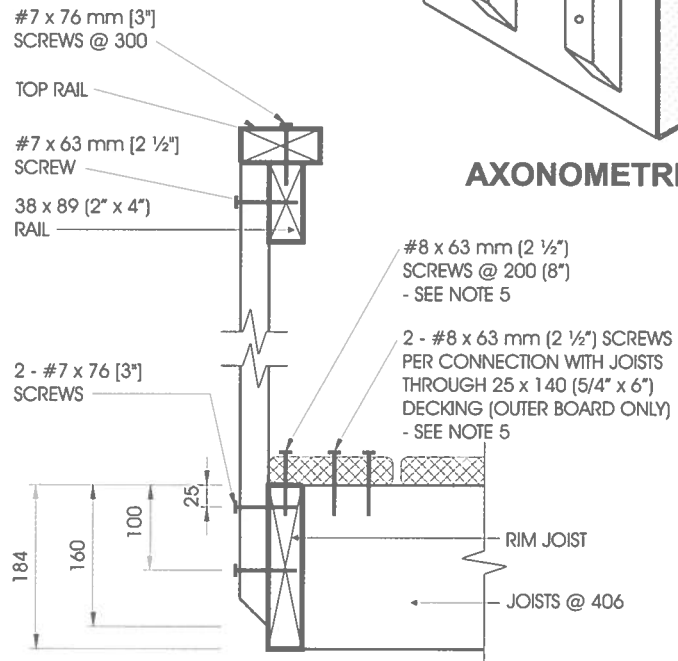

SIDE ELEVATION

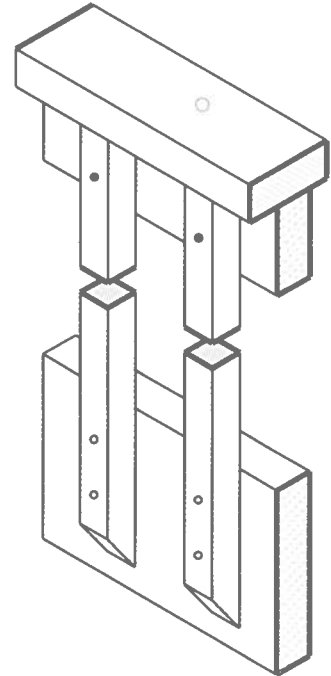

AXONOMETRIC

Detail ED-1

Exterior Connection: Cantilevered Picket Screwed to Rim Joist

Notes:

1. Provide a suitable post, return, or solid support at each end of the guard.
2. Wood for cantilevered pickets shall be Douglas Fir-Larch, Spruce-Pine-Fir, or Hem-Fir Species.
3. Fasten rim joist to each floor joist with 3 - 82 mm (3 1/4") nails.
4. Dimensions shown are in mm unless otherwise specified.
5. The outer deck board shall not be less than 140 mm (6" nominal) wide. Where 38 mm (2" nominal) thick boards are used, the length of the wood screws shall be not less than 76 mm (3").

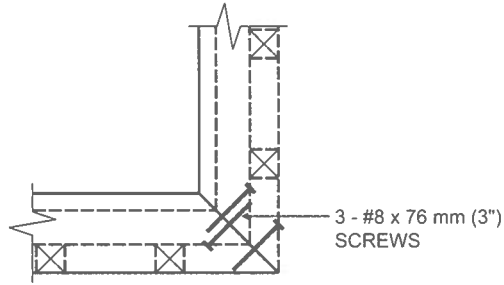

PLAN TOP RAIL

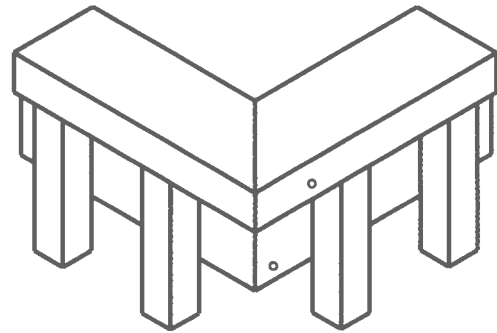

AXONOMETRIC

ONE FASTENER IN HORIZONTALLY ORIENTATED PORTION OF TOP RAIL
AND TWO IN VERTICALLY ORIENTATED PORTION.

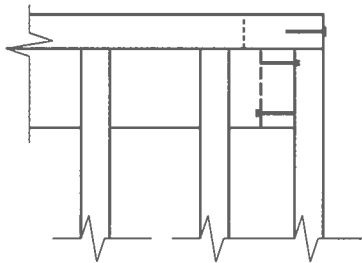

FRONT TOP RAIL

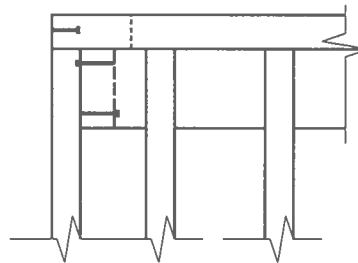

SIDE TOP RAIL

Detail ED-5

Exterior Connection: Corner Joint

Notes:

- 1. Screws fastening pickets are omitted for clarity.
- 2. Provide a minimum of 10 pickets beyond the return if end restraint of the guard is provided by this return detail only.